

# ZEISS V8 NA

User's Guide – North America



2.8-20x56



4.8-35x60



---

**PRECISION RIFLESCOPES FOR YOUR HUNTING AND SHOOTING ADVENTURES**

---

ZEISS Limited Lifetime  
Transferable Warranty  
and Five-Year No-Fault  
Policy

---



## TABLE OF CONTENTS

V8 NA Anatomy: 2.8-20x56, 4.8-35x60 Models	3
Magnification/Zoom Adjustment	5
Focusing the Reticle	5
Reticle Illumination	6
Parallax Adjustment	6
Battery Replacement	7
Riflescope Installation	7
Leveling the Reticle	9
Establishing a Sight-In Zero	9
External Elevation Turrets with Ballistic Stop: 2.8-20x56, 4.8-35x60 Models	11
Capped Windage Turrets: 2.8-20x56, 4.8-35x60 Models	13
Reticles (Second Focal Plane)	14
V8 NA Schematic and Magnification Throw Lever	15
Caring for Your Riflescope	16
Battery Warning	17
Service / Product Returns	18
V8 NA Specifications	19
Warranty and Five-Year No-Fault Policy	Back Cover

### **WARNING!**

Always make sure that your rifle is unloaded prior to mounting or dismounting your riflescope.

ZEISS Sports Optics is not responsible for typographical errors. Product images are for illustration purposes only. Specifications and products may change without prior written notice. All efforts have been made to make sure content is accurate at time of printing.

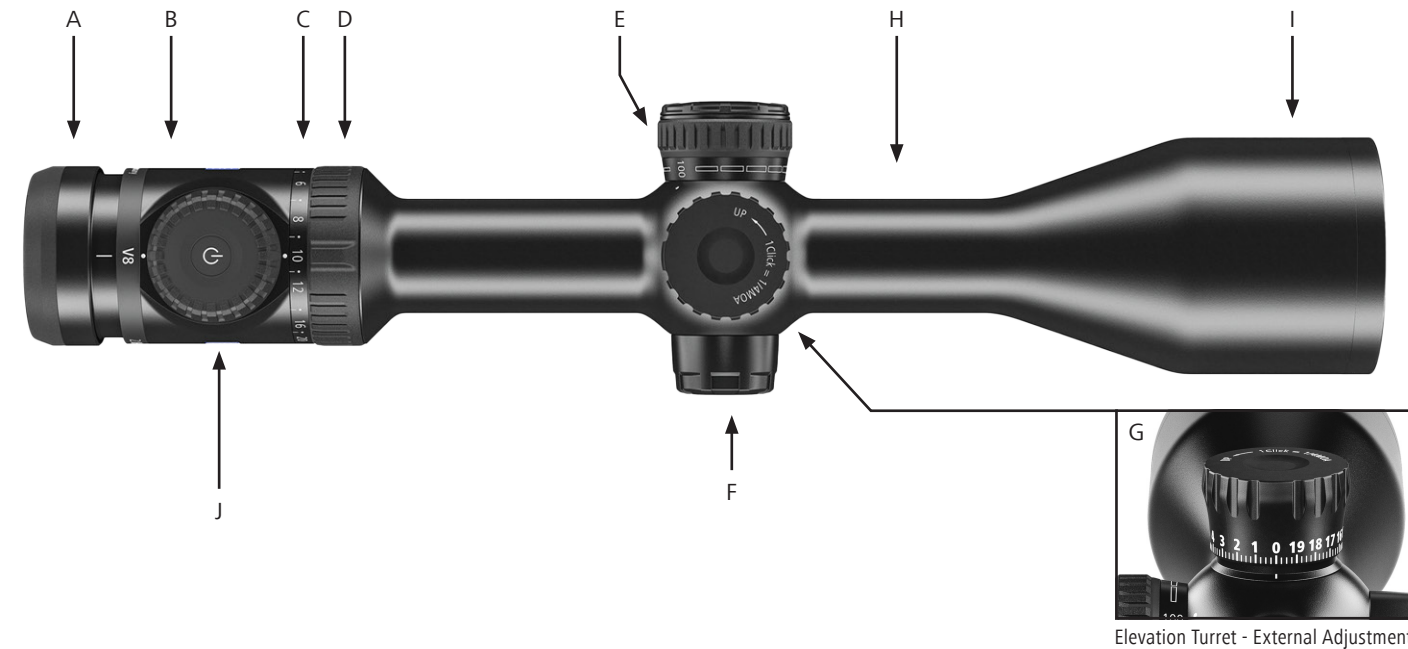

## V8 NA ANATOMY

2.8-20x56 and 4.8-35x60 Models

- |                                       |  |
|---------------------------------------|--|
| A: European-Style Fast Focus Eyepiece | F: Capped Windage Turret                         |
| B: Ocular Housing                     | G: External Elevation Turret with Ballistic Stop |
| C: Magnification/Zoom Indicator       | H: Main Tube (30mm or 34 mm)                     |
| D: Magnification/Zoom Adjustment      | I: Objective                                     |
| E: Parallax Adjustment                | J: Reticle Illumination                          |



**2.8-20x56**  
(30 mm)

**4.8-35x60**  
(34 mm)



**! WARNING!**  
Do **NOT** look directly at the sun or other bright lights through the rifle scope. Doing so may cause eye damage or blindness.

**MAGNIFICATION/ZOOM ADJUSTMENT**

The magnification/zoom adjustment allows for the shooter to select the desired magnification setting. The shooter can accomplish this task by rotating the adjustment while referencing the magnification/zoom indicator scale, located on the ocular housing, and while referencing the magnification/zoom adjustment alignment indicator. (See Image 1a.) This is a frictional adjustment, and it is designed to incorporate felt resistance during adjustment. Therefore, it should remain in position until the shooter adjusts it further.

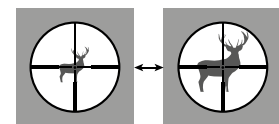

1a. Lower magnification setting with more field of view; higher magnification setting with less field of view

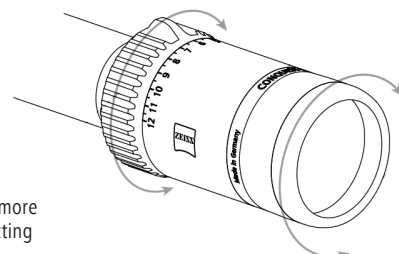

1b. European-style fast focus eyepiece

**FOCUSING THE RETICLE**

The diopter adjustment and the parallax adjustment aid in creating a better sight image and aiming point. The reticle image should be clear, crisp, and in focus. The European-style fast focus eyepiece is the diopter adjustment, and it is used for establishing the reticle's focus to match your particular vision/corrected vision. If you plan to wear corrective vision glasses when shooting, then set this focus while wearing your corrective glasses or using contact lenses. The reticle focus should be established before setting the parallax adjustment. If the diopter adjustment is set to the extreme position of travel, it can negatively affect parallax. Once set, this setting is good for the season and should then be checked from time to time. **Note: ZEISS recommends initially setting the diopter adjustment to neutral/zero setting and adjusting from this position if necessary.**

**Reticle Focus Adjustment**

In order to adjust the European-style fast focus eyepiece to establish an appropriate diopter setting, simply turn the eyepiece either inward or outward to achieve the preferred setting. (See Image 1b.)

1. Begin at the highest magnification setting.
2. Set parallax to the infinity setting ∞. (Dependent upon model.)
3. Look through the riflescope at a neutral colored background, such as a white or gray wall, or cover the objective lens with a light cloth to eliminate distracting background. Determine if the reticle is clear and in focus as soon as you view through the eyepiece. Note that staring at the reticle for more than about two seconds during this setup will cause your eye to begin to compensate for focus, resulting in a false indication of the reticle's true



focus. Try to assess a few seconds at a time, looking away for about 5-10 seconds, and then view again to determine results. Your goal is to view a crisp and highly focused reticle image – without straining your eye.

- If adjustment is necessary, follow these steps: Because of the way your eye focuses, ideal results are typically obtained by turning the eyepiece inward until the reticle is slightly blurred, then moving it outward until sharp focus is obtained. (See Image 2a.)

Once you are satisfied with the reticle’s focus, note the position of the eyepiece for quick reference in the future.

**PLEASE NOTE: While using the riflescope, if the reticle tends to go in and out of focus or eye strain is present with shooting sessions, this is an indicator that the reticle needs to be focused/refocused for your eye.**

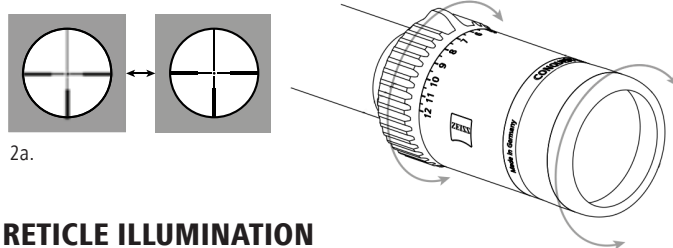

## RETICLE ILLUMINATION

ZEISS V8 NA riflescopes feature the digital illumination option for the reticle. The reticle’s digital illumination control allows for adjustment of the intensity of the illumination. The digital angle sensor further controls the illumination, via auto on/off feature while rifle is in use.

### Reticle’s Illumination On/Off and Adjustment Settings (Located on Reticle’s Illumination Control/Adjustment)

To illuminate the reticle, press the center button of the reticle control/adjustment. The reticle will default to the intensity setting used previously. With the reticle switched on, you can rotate the illumination control to adjust the intensity of the illumination to your preferred setting. To turn off the illumination, press the same button for approximately 1-2 seconds. *After three hours of inactivity of the riflescope, the reticle will automatically turn off.*



## PARALLAX ADJUSTMENT

ZEISS V8 NA riflescopes incorporate a side parallax adjustment, and the adjustment range is from 50 yards to infinity. V8 NA models that do not offer this feature have a fixed parallax setting of 100 yards.

Parallax is the apparent movement of the reticle in relation to the target as the shooter moves his eye across the exit pupil of the riflescope. This condition is caused by the target and the reticle appearing on different focal planes within the riflescope. (See supporting imagery below.)



Distance about 100 yards: Image and reticle are located in a single plane (parallax absent).



Distance about 300 yards: Image plane is behind the reticle (parallax present).

The goal is to remove the parallax sighting error by adjusting the focus settings via the parallax adjustment.

When parallax is present while shooting at longer distances and at higher magnification settings, it can easily result in relevant sighting errors. For the most accurate and best shooting results, the shooter should constantly check for parallax and remove it when necessary via the side parallax adjustment, especially when shooting at targets at varying distances.

### Adjusting to Remove Parallax

Check for parallax with the rifle in a stable position and while looking through the riflescope at a defined point on the target. If parallax is present, while moving your head up and down, you will witness it. When parallax is present, the reticle will appear to move slightly up and down, even though the rifle and riflescope are stationary. If the reticle remains stable across the defined point of aim, while moving your head up and down while looking through the riflescope, then parallax has been removed.

To eliminate parallax, rotate the parallax adjustment until the reticle remains stable in relation to the target, regardless of head movement.

## BATTERY REPLACEMENT (SEE BATTERY WARNING PAGE 17)

The battery is located below the reticle’s illumination control cap. It is removed by turning the knurled cap counterclockwise. ZEISS suggests replacing the battery in a controlled environment in order to reduce contamination to the battery compartment and ensure you more easily maintain control of the cap.

In regard to reticle illumination, a fresh battery has an estimated run time of over 700 hours when set at the lowest intensity level. Replace depleted

Artwork is for illustrative purposes. Actual product may vary slightly in appearance.

batteries with a quality CR2032 battery or equivalent. Install the battery with the positive (+) side up. To help prevent premature battery discharge, the auto off feature will engage due to the rifle’s angle, position, or inactivity of the rifle.

*Battery run times can be adversely impacted by colder temperatures.*

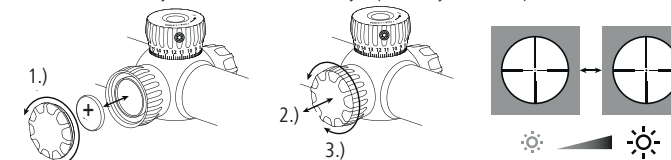

- 1) Unscrew cap and replace battery.
- 2) Screw on cap and pull out on the reticle control/adjustment.
- 3) Adjust to control intensity.



**! WARNING!**  
**STOP! Make sure your rifle is unloaded, the chamber is empty, and the action is open prior to installing your ZEISS riflescope.**

## RIFLESCOPE INSTALLATION

**POOR OR IMPROPER MOUNTING OF THE RIFLESCOPE CAN CAUSE EQUIPMENT AND/OR PERSONAL DAMAGE, WHICH CAN RESULT IN SERIOUS EQUIPMENT DAMAGES, AS WELL AS PERSONAL INJURY OR DEATH.**

**ZEISS strongly recommends that you use high quality mounting solutions that appropriately fit the riflescope model. Follow the manufacturer’s torque specifications for successful mounting of rings, bases and mounting solutions.**



### Ring and Base Selection (Rings Required: 30 mm or 34 mm)

To optimize the performance of the riflescope and mounting solutions, ZEISS recommends the following:

- Use a high-quality ring and base combination that properly fits the rifle as well as the riflescope model.

## ! WARNING!

**Recoil is real energy, and it can be dangerous for the shooter! Please be certain that your installation provides maximum eye relief. Pay attention to this warning, especially when shooting uphill and/or from a prone position. Shooting conditions such as these can dramatically reduce eye relief. PLEASE MAINTAIN MAXIMUM EYE RELIEF!**

### Mounting the Base to the Action

Attach the base to the action, and follow the torque setting for the mounting screws provided by the manufacturer. Ensure the mounting screws and threaded holes are clean and free of grease and contaminants.

### Mounting the Rings to the Base

Ensure that the inside surfaces of the rings and the surface of scope tube are clean and free of grease.

Ensure that the height of the rings will allow for adequate clearance of the objective and barrel surface. If you plan to use flip-up or pull-over lens covers, consider the additional space requirements for those at this time. Install the rings on the base per the manufacturer's specifications. Take care to position the rings where they will not make contact with the turret assembly body, the objective bell-to-tube transition point, or the magnification/zoom adjustment transition point.

Ensure that the riflescope lies into the rings stress-free. Damage to the riflescope or riflescope's finish resulting from improper alignment, lapping, and installation is not covered by the warranty.

### Mounting the Riflescope

1. For initial fit of the riflescope to the rifle, set the riflescope to the highest magnification. Place the riflescope in the rings as far forward as possible. Tighten the ring screws with minimal tension to gently but safely hold the riflescope where positioned. This initial step should just allow the scope to move back and forth for Step 2 listed below
2. Place the rifle in your normal shooting position. Place your head as far forward on the stock as you might position it in field use. Slowly move the riflescope back just to the point where the full field of view is obtained. ZEISS recommends mounting the riflescope at this position to **ensure maximum eye relief.**

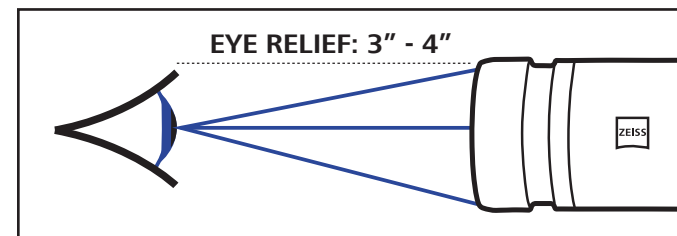

**Note: While wearing thick clothing, you may need to adjust your riflescope mounting location to accommodate for maximum eye relief.**

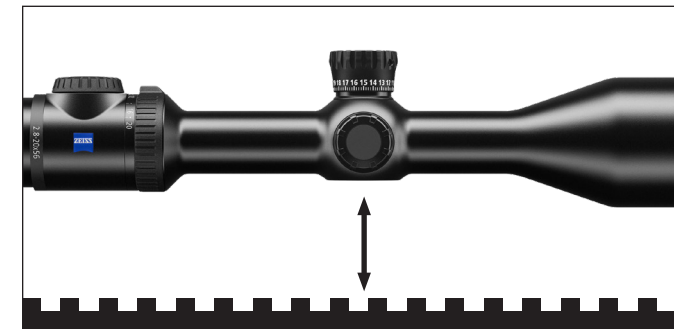

These two surfaces should be parallel to each other.

## LEVELING THE RETICLE

For precise shot placement, the reticle and the rifle need to be squared, or plumb, to each other. This will reduce sighting errors that will be magnified as distance to target is increased.

The reticles in ZEISS riflescopes are plumb with the flat surface on the bottom of the riflescope. To level the reticle using a plumb line, follow these helpful steps:

1. Ensure the rifle is unloaded and is level and affixed in a steady rest or sandbags throughout this procedure.
2. While viewing through the riflescope, reference a plumb line or plumb target frame at a suggested distance of approximately 100 yards.

3. From the shooting position, center/align the reticle on the plumb line for reference, and rotate the riflescope in the rings until the vertical line of the reticle is parallel with the plumb reference line. Be patient with this process, and double check the rifle's position. Rotate the riflescope as needed to align the reticle with the plumb line.

When all is adjusted and aligned properly, finalize the tightening of the ring screws evenly to secure the riflescope in the rings.

Torque the ring screws to the recommended torque settings. Your ZEISS riflescope should now be mounted and secured in the proper position.

## ESTABLISHING A SIGHT-IN ZERO

**NOTE: The elevation and windage turrets' adjustment settings are set at the halfway position of the riflescope's total adjustment value available, from the factory. To access the total adjustment travel value, the elevation turret's Ballistic Stop must be loosened to further maximize total travel adjustment available.**

**Please visit [www.zeiss.com/us/sports-optics](http://www.zeiss.com/us/sports-optics) for a video tutorial on this process and setting methods that can maximize the performance of your Ballistic Stop configured riflescope.**

In order to save time and ammunition and achieve proper results with the least amount of effort, ZEISS suggests you have the riflescope bore sighted by an appropriate gunsmith or service center that deals in riflescope mounting. You can also accomplish this task by looking down the barrel's bore at a high contrast target, approximately 6" in diameter. The target can be mounted at

a distance of 25, 50, or 100 yards for the best solution. The selected target should be easy to see from any of these distances. While the target may be only 6" in diameter, ZEISS recommends using a white paper backer of at least 24" x 24" in size. This will allow you to visualize and plot your shot placement with ease.

1. Confirm that the rifle is unloaded and the chamber is empty. Affix the rifle in a steady rest, and remove the bolt assembly.
2. While looking down the bore's centerline, from the action end, (A1) center the target in the bore. The target should appear in the center of the barrel's bore. (A2) With rifle held in position, not allowing it to move, adjust the elevation and windage turrets until the reticle is aligned in the center of the 2-3 shot group from step 3. If you have run out of elevation adjustment/travel, refer to the next section covering the Ballistic Stop Turret to see how to access further adjustment/range of travel.

3. With the bore sighting process completed, you can begin live firing sight-in at the respective 25, 50, or 100 yards. ZEISS recommends two or three confirmation shots. After confirming your point of impact, proceed to the next step.

PLEASE NOTE: Because MOA is an angular unit of measure, if you have sighted in at 25 yards, while referencing .25 MOA adjustments, you will need to adjust the travel four times more than you would with a 100-yard sight-in. Also, if you sighted in at 50 yards, while referencing .25 MOA adjustments, you will need to adjust the travel two times more than you would with a 100-yard sight-in. If you are sighting in at 100 yds, and the

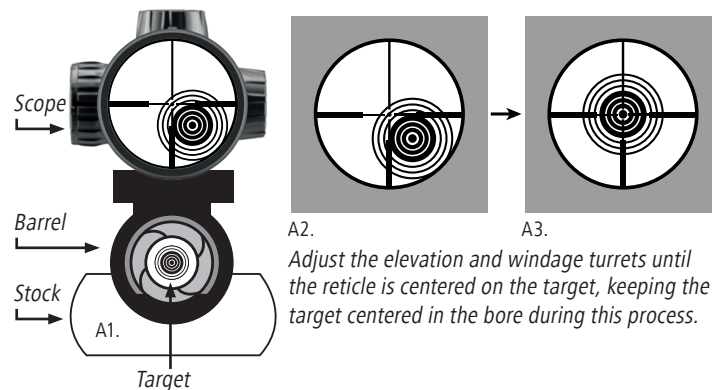

first shot is not on the target backer paper, ZEISS suggests you move to a 25-yard sighting distance.

4. It is now time to aim the rifle and center the reticle on the intended sight-in target from step 3. While holding the rifle steady on the center of the target and ensuring it doesn't move, while looking through the riflescope, adjust the elevation and windage turrets until the reticle is aligned in the center of the 2-3 shot group from step 3. If you have run out of elevation adjustment/travel, refer to the next section covering the Ballistic Stop Turret to see how to access further adjustment/range of travel.
5. ZEISS suggests you shoot a three-shot group at the sight-in target/close-range zero distance. When this is accomplished, allow the barrel to cool, and then fine tune the riflescope's zero with final elevation and windage adjustment corrections, to your preferred target distance. Confirm your preferred and final zero and zero sight-in distance with another three-shot group.

## EXTERNAL ELEVATION TURRETS WITH BALLISTIC STOP: 2.8-20x56 AND 4.8-35x60 MODELS

ZEISS V8 NA riflescope models incorporate an external, non-locking, multi-turn elevation turret, with a Ballistic Stop feature. The turret's multi-turn design allows for the maximum use of the riflescope's elevation travel above your established zero. This further allows for greater elevation adjustment range that supports target engagement at longer distances. **The ZEISS Ballistic Stop** allows for a definitive stop when the turret is returned to zero.

Note: The O-rings underneath the turret assembly must be clean and free of defects and debris. While setting and adjusting the Ballistic Stop, please ensure that these mechanical components remain free of dirt and contaminants. If you are satisfied with your ammunition selection and zero/sight-in, follow these instructions to finalize the setting of the Ballistic Stop feature:

1. Remove the elevation turret cap by **loosening** the two set screws; however, **do not remove the screw(s) entirely**. The cap can now be lifted off of the turret assembly. (See Image 1.)
2. You may feel slight resistance while lifting off the cap. You should NOT feel any clicks at this time; if you do, the turret cap set screws should be loosened further. Place the turret cap aside on a clean surface. Take care to keep the inside of the turret cap clean and free of debris. (See Image 2.)
3. The Ballistic Stop assembly is now exposed. Maintain the cleanliness of the Ballistic Stop assembly. (See Image 3.)
4. Loosen – but do NOT remove – each of the set screws on the Ballistic Stop barrel assembly. (See Images 4a, 4b, and 4c.) Note the cam at the bottom of the barrel stem assembly. Note the stop step at the top of the turret's base assembly. When these two surfaces engage, this establishes the firm stop position of the Ballistic Stop.

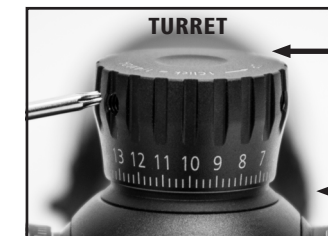

1. Loosen the set screws.



2. Place the turret aside on a clean surface.



3. Internal turret assembly.

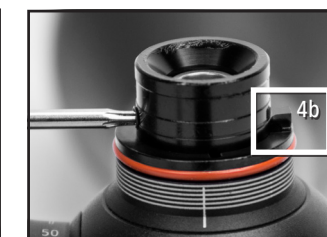

4a. Ballistic Stop screws (x2).

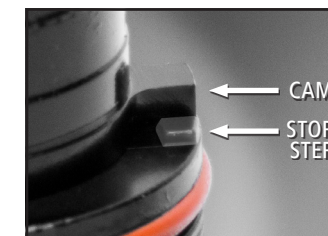

4b. Cam and stop step engaged, establishing firm stop position of Ballistic Stop.

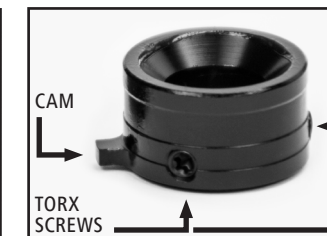

4c. Barrel assembly with cam.



5a. Rotate the slotted portion of the turret stem assembly either downward or upward to your selected zero position.

5. With the Ballistic Stop barrel assembly loosened, remove it and rotate the slotted portion of the turret stem assembly either downward or upward to your selected zero position. (See Image 5a.) Once your desired sight-in zero is achieved, reinstall the Ballistic Stop barrel assembly. (See Image 5b.) Rotate it clockwise (from the shooter's position) until the cam contacts the stop step (See Image 4b, for proper positioning of the Ballistic Stop cam and stop step.) Tighten the set screws while holding the barrel assembly in place.

6. While holding the Ballistic Stop barrel assembly mechanism in proper position, tighten the two T8 set screws to ~5.3 in-lbs. Do NOT over tighten the screws. If you do not have a calibrated torque driver, ZEISS suggests you hold the short end of the provided Torx™ wrench between your thumb and finger and turn the Torx™ wrench approximately 1/8 - 1/4 turn past initial resistance to obtain a secure position setting. Improper torque settings can cause the Ballistic Stop to slip during turret adjustment.

5b. Reinstall the barrel assembly.

7. Check to be sure the entire assembly is clean and free of debris, replace the turret, center it over the turret body assembly, and press down lightly into position. Maintain slight downward pressure on the cap, align the cap's engraved numerical "0"/zero index mark with the vertical engraved center line on the turret's base housing, and tighten both T8 set screws to ~5.3 in-lbs. If you do not have a calibrated torque driver, ZEISS suggests you hold the short end of the provided Torx™ wrench between your thumb and finger and turn the Torx™ wrench approximately 1/8 - 1/4 turn past initial resistance to obtain a secure position setting. Improper torque settings can cause the turret's cap to slip during turret adjustment.

7. Reinstall the turret aligning the turret's engraved numerical zero with the vertical center line.

## CAPPED WINDAGE TURRET: 2.8-20x56 AND 4.8-35x60 MODELS

ZEISS V8 NA riflescopes incorporate a capped windage turret. The capped windage adjustment is waterproof, even with the caps removed, and can be used without the cap installed. See illustrating images above.

1a. Regarding the capped windage turret adjustment, remove the protective cap by rotating it in a counterclockwise direction.

1b. With the cap removed, the windage turret is now accessible and can be adjusted in either direction for appropriate sight-in correction for both left and right sighting corrections.

1c. Once your sight-in is established, re-index to the turret's numerical "0"/zero setting by simply pulling out the windage turret's outer ring and freely rotating it to index the zero position. You should not feel any clicks when pulling out and rotating the windage turret's outer ring to the indexed "0"/zero position.

1d. Replace the windage turret's cap.

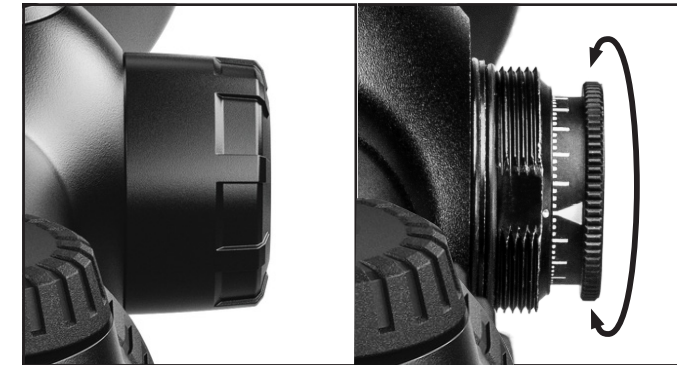

1a. Rotate in a counterclockwise direction to remove the protective cap. 1b. Exposed windage turret. Rotate left or right to adjust for sight-in correction.

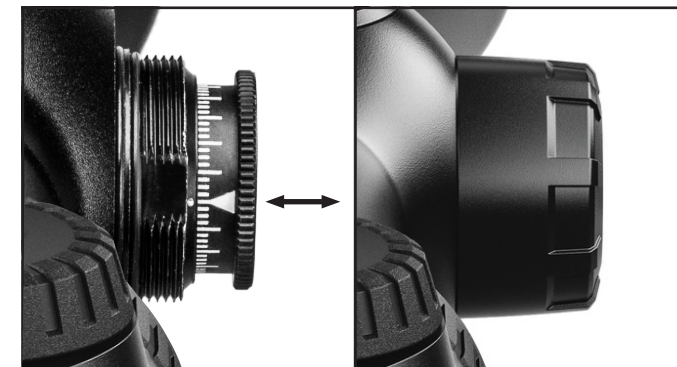

1c. Pull out the windage turret's outer ring and freely rotate it to index the zero position. Release the turret's outer ring. 1d. Replace the windage turret's cap.



## RETICLES (SECOND FOCAL PLANE)

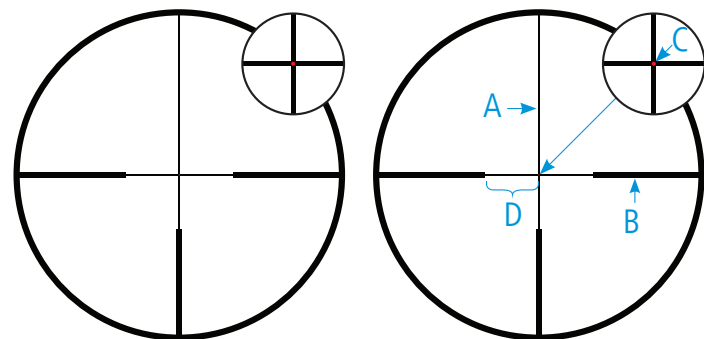

RETICLE TYPE **Plex-Style with Dot** RETICLE # **60**

### ILLUMINATED

RIFLESCOPE(S)	V8 2.8-20x56	V8 4.8-35x60
Magnification	@ 20x	@ 35x
	<b>MOA</b>	<b>MOA</b>
Line Thickness A	0.17	0.10
Bar Thickness B	0.85	0.51
Dot Size C	0.1	0.08
Opening D	14	8

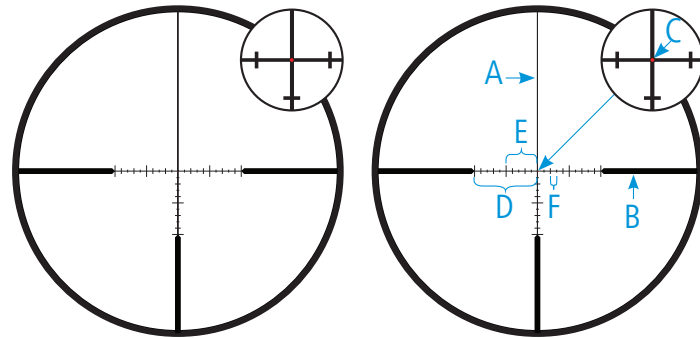

RETICLE TYPE **AHR** RETICLE # **90**

### ILLUMINATED

RIFLESCOPE(S)	V8 2.8-20x56	V8 4.8-35x60
Magnification	@ 20x	@ 35x
<b>UNIT OF MEASURE</b>	<b>MOA</b>	<b>MOA</b>
Line Thickness A	0.17	0.10
Bar Thickness B	0.85	0.51
Dot Size C	0.12	0.08
Opening D	10	10
Distance E	5.00	5.00
Distance F	1.00	1.00

## V8 NA SCHEMATIC – EXTERNAL DIMENSIONS

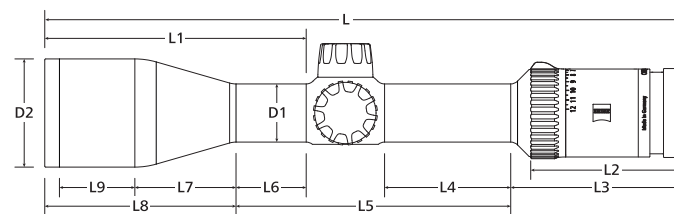

Ocular Housing Diameter: 1.85 inches

Riflescope Model	D1	D2	L	L1	L2	L3	L4	L5	L6	L7	L8	L9
V8 NA 2.8-20x56	30	2.44	13.78	5.73	3.43	3.84	2.36	5.94	1.74	2.22	4.0	1.48
V8 NA 4.8-35x60	34	2.64	15.73	7.77	3.43	3.80	2.48	6.45	2.29	2.72	5.48	2.52

Measurements above are listed in inches, unless otherwise noted.

## MAGNIFICATION THROW LEVER (OPTIONAL ACCESSORY)



**Note:** Actual product may vary slightly than image illustrated above.



## CARING FOR YOUR RIFLESCOPE

Ensure your ZEISS riflescope is NOT exposed to extreme heat over prolonged periods of time, such as those elevated temperatures sometimes found inside of a vehicle on a sunny day.

Your ZEISS riflescope is designed and manufactured to give you many years of reliable and long-term service. One of the best ways to protect your optical investment is to be sure and use appropriate lens covers when you are not using your riflescope. To further protect your riflescope, ZEISS strongly suggests you keep the product clean and free of troublesome sand, dirt, salt water, and various contaminants.

### Cleaning Your ZEISS Riflescope's Exterior

For a heavily soiled riflescope, you can rinse the riflescope under a stream of cool or warm water, and then wipe it down with a water-moistened towel. Do not use strong solvents to clean your riflescope or its optics. Using such solvents will void the ZEISS warranty.

**STOP: CONFIRM CHAMBER IS EMPTY AND RIFLE IS UNLOADED.** When cleaning your rifle and rifle barrel, **PLEASE ENSURE THAT THE RIFLESCOPE'S LENS COVERS ARE IN PLACE FIRST.** These types of cleaning solvents can and will destroy the fine and precision multi-layer lens coatings.

### Cleaning Your Lenses

ZEISS recommends using original ZEISS branded lens cleaning solutions, supplies, and complete cleaning kits to care for the lenses on your riflescope.

First, permit heavy or large debris on the lens surfaces to fall away from the surface. Try to carefully remove loose dirt and dust with a lens brush.

**STOP:** Do **NOT** use the types of compressed air cans found typically in the office supply section of various retail outlets. When used improperly, they can destroy lens coatings, causing the coatings to peel away or blister from the lens surface.

You can also remove stubborn grit and other contaminants by gently flushing the surface with distilled water. With these larger contaminants removed, you can now gently swab the lenses clean by following the respective lens cleaning instructions.

ZEISS strongly suggests using a clean, lint-free, pre-moistened microfiber cleaning cloth or appropriate lens swab and an appropriate lens cleaning solution. Starting in the center of the lens, begin swabbing in a circular motion, working toward the outside. Once you reach the outer diameter of the lens you are cleaning, use a new swab or another portion of the microfiber cloth to avoid streaking the lenses with contaminants and grease frequently located where the lens comes in contact with the metal lens housing. Make only one pass to the edge where the glass meets the metal. Repeat this process as necessary until desired results are achieved. TIP: Use only a small amount of cleaning solution for the final lens swabbing to prevent streaks.





### Long-Term Storage

ZEISS suggests you remove the battery – where applicable – if the riflescope will not be used for a prolonged period of time. Store the riflescope in a cool, dry, clean, and contaminant-free location.

## WARNING:

- Do not place riflescopes in the hands of children, small parts can come loose and be swallowed. This may result in a suffocation hazard.



## BATTERY: (When your product is equipped with an illuminated reticle)



 <b>WARNING</b>	
<p><b>INGESTION HAZARD:</b> This product contains a button cell or coin battery. <b>DEATH</b> or serious injury can occur if ingested. A swallowed button cell or coin battery can cause Internal Chemical Burns in as little as 2 hours.</p> <p><b>KEEP</b> new and used batteries <b>OUT OF REACH</b> of CHILDREN. <b>Seek immediate medical attention</b> if a battery is suspected to be swallowed or inserted inside any part of the body. In the event of swallowing, consult a doctor immediately. For treatment information in the US call: 1-800-498-8666. For treatment information in Australia call: 131 126. For all other countries: Call a local poison control center for treatment information.</p>	  

- Even used batteries may cause severe injury or death.
- Remove and immediately recycle or dispose of used batteries according to local regulations and keep away from children. Do NOT dispose of batteries in household trash or incinerate.
- Replace only by non-rechargeable battery type CR2032 with nominal battery voltage of 3V.
- Non-rechargeable batteries are not to be recharged.
- Do not force discharge, recharge, disassemble, heat above (manufacturer's specified temperature rating) or incinerate. Doing so may result in injury due to venting, leakage or explosion resulting in chemical burns.
- Handle used batteries according to the battery manufacturer's instructions.
- Ensure the batteries are installed correctly according to polarity (+ and -).
- Do not mix old and new batteries, different brands or types of batteries, such as alkaline, carbon-zinc, or rechargeable batteries.

- Remove and immediately recycle or dispose of batteries from equipment not used for an extended period of time according to local regulations.
- Always completely secure the battery compartment. If the battery compartment does not close securely, stop using the product, remove the batteries, and keep them away from children.

## WARNINGS FOR PROPER HANDLING:

 <b>WARNING</b>	
<p><b>OPTICAL RADIATION HAZARD:</b> This product focuses light and can act like a burning glass. <b>SEVERE INJURY OF THE EYES</b> can occur this riflescope is aimed at strong light sources. <b>Never LOOK AT LIGHT SOURCES</b> such as the sun, flashlights, or lasers with the riflescope.</p>	

 <b>WARNING</b>	
<p><b>FIRE HAZARD:</b> This product focuses light. <b>DANGER DUE TO FIRE:</b> The objective lens and eyepiece can function as a burning glass and damage the interior components as well as burn objects behind it. <b>Do not point the riflescope at intense light sources. Never leave the device in the sun without the protective lens cap.</b></p>	

- Always check and ensure that the firearm is unloaded before working on the riflescope mounted on the weapon.
- To prevent injury, ensure that there is sufficient eye relief when mounted.
- Before using, ensure that your riflescope is in proper working condition.
- Look through your riflescope to test if the optics provide a clear, undisturbed image.
- If handled roughly, a maladjustment cannot be ruled out.
- Test the correct setting on the reticle using controlled shots.
- Avoid touching the metal surface after exposure to sunlight or cold.

## CONSUMER PRODUCT RETURNS – NORTH AMERICA

**STOP:** Before sending a riflescope in for service, please call ZEISS Sports Optics Customer Care team at the number below in order to determine if the issue/concern can be resolved without having to return the product.

**1-800-441-3005**  
**info.sportsoptics.us@zeiss.com**

After your initial inquiry, if it was determined that your ZEISS product needs to be sent in for evaluation, service, or repair, Customer Care can assist you in accessing the secure online Repair Form. Please complete all sections of the Repair Form before submitting it. It is particularly important that you provide a phone number and email address (if possible) so that ZEISS can communicate with you about your case. Upon submitting the Repair Form, you will see a printable document containing your case number and the shipping address of our service facility. Please include a copy of this document with the product you send us, and keep one for your records. If you are unable to complete the online Repair Form due to a lack of internet access, Customer Care can advise you on how to ship your product to us along with all the information we will need to create a service case for you.

**Be sure to place the appropriately wrapped and protected product in a proper shipping container. Insure it for replacement value, and ship it shipping prepaid to the appropriate address listed below.**

**USA Residents: Please send to ZEISS Service/Repair Dept.**

ZEISS Consumer Products  
 1050 Worldwide Blvd.  
 Hebron, KY 41048-8632  
 P: 1-800-441-3005

**Canadian Residents: Please send to ZEISS Authorized Distributor:**

Gentec  
 90 Royal Crest Court  
 Markham, Ontario  
 CANADA L3R 9X6  
 P: 905-513-7733

**Rest of the World:**

Due to legal requirements and export/import restrictions, any product exported or sold outside the United States and Canada must be returned to the original point of purchase, with a copy of the invoice or your product registration information.

**DO NOT** return exported items directly to Carl Zeiss SBE, LLC from outside the United States.

**DO NOT** return exported items directly to Gentec International from outside Canada.

**Carl Zeiss SBE, LLC and Gentec International cannot accept products from, or ship products to, locations outside the United States and Canada respectively.**

*This document is subject to improvements and changes without prior written notice.*

## SPECIFICATIONS

	V8 NA	
<b>Model</b>	2.8 – 20×56 NA	4.8 – 35×60 NA
Magnification	2.8 x – 20 x	4.8 x – 35 x
Focal Plane	Second	Second
Effective Lens Diameter	27.5 mm – 56 mm	48.1 mm – 60 mm
Exit Pupil Diameter	9.9 mm – 2.8 mm	9.9 mm – 1.7 mm
Twilight Factor	7.9 – 33	13.6 – 45.8
Field of View at 100 yds	45.9 ft – 6.3 ft	25.8 ft – 3.6 ft
Angular Field of View, Real	8.8° – 1.2°	4.9° – 0.7°
Dioptr Range	- 3.5 / + 2 dpt	
Eye Relief	3.6 in (92 mm)	
Parallax Setting	50 m – ∞	50 m – ∞
Elevation Adjustment Range	72 MOA	48 MOA
Windage Adjustment Range	46.5 MOA	29 MOA
Click Value	0.25 MOA	
Main Tube Diameter	30 mm	34 mm
Eyepiece Tube Diameter	46 mm	
Objective Tube Diameter	62 mm	67 mm
Coating	LotuTec® / ZEISS T*	
Fogproof	Nitrogen Purged	
Waterproof	400 mbar (submerged 13 ft for 2 hours)	
Operating Temperature	-13° F / +122° F	
Length	13.8 in	15.7 in
Weight / with Illumination	28.8 oz	34.6 oz
Reticles (Second Focal Plane)	AHR or #60	AHR or #60

**V8 NA:** Represents the newest configurations of ZEISS' flagship riflescopes, consisting of MOA-based reticles and turrets. Turret adjustments incorporate 0.25 MOA click value and utilize traditional rotation directions as is typical for North America. The external, multi-turn, elevation turret, with the Ballistic Stop feature is standard for these riflescopes – along with capped windage turrets.

ZEISS Sports Optics is not responsible for typographical errors. Product images are for illustration purposes only. Specifications and products may change without prior written notice. All efforts have been made to make sure content is accurate at time of printing.

For the latest updates and information regarding our products, visit [zeiss.com/consumer-products/us/hunting.html](http://zeiss.com/consumer-products/us/hunting.html)

V8 NA USER'S GUIDE - NORTH AMERICA | 19



ZEISS Sports Optics is not responsible for typographical errors. Product images are for illustration purposes only. Specifications and products may change without prior written notice. All efforts have been made to make sure content is accurate at time of printing.



# ZEISS Transferable Limited Lifetime Warranty and Transferable Five-Year No-Fault Policy

At ZEISS North America we back your Sports Optics purchase with a limited lifetime warranty as well as a five-year no-fault policy – both fully transferable.

The warranty protects against defects in workmanship and materials in the Optical System for the life of the product, and in electronic components for five years from the date of purchase. Components and accessories (such as lens caps) are warranted for one year from the date of purchase. If a ZEISS product has a defect covered by this warranty, we will either repair it, or replace it, with a new or reconditioned ZEISS product of comparable specifications. Please note that certain specialty products (such as stabilized binoculars and DTI thermal cameras) have shorter warranty periods.

ZEISS understands that accidents happen, so in addition to the limited lifetime warranty, we offer the added protection of our transferable Five-Year No-Fault Policy on select Victory, Conquest, V8, SFL and LRP products. If you accidentally damage your product during normal and intended use within the first five years of the life of the product, we will either repair it, or replace it, at no cost to you.

To view the complete details of the Transferable ZEISS Limited Lifetime Warranty and Transferable Five-Year No-Fault Policy, please visit:  
[zeiss.com/consumer-products/us/service.html](https://zeiss.com/consumer-products/us/service.html)

# ZEISS HUNTING APP

iOS / Android  
Compatible

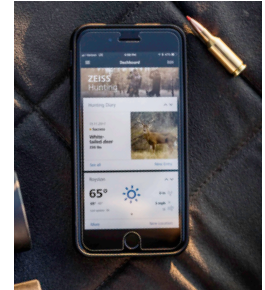

In order to maximize the use, features, and benefits of your ZEISS riflescope, we invite you to download the ZEISS Hunting App. This free app offers unique and easy-to-use information at your fingertips.



[zeiss.com/consumer-products/us/hunting](https://zeiss.com/consumer-products/us/hunting)

## Customer Service

1-800-441-3005  
[info.sportsoptics.us@zeiss.com](mailto:info.sportsoptics.us@zeiss.com)

**Carl Zeiss SBE, LLC**  
Consumer Products

  | JOIN THE CONVERSATION

09/2024 | SAP# 000000-2702-482 (User's Guide – V8 NA)



Seeing beyond