

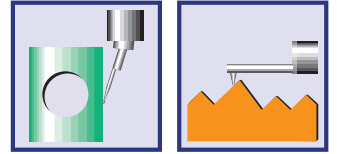

RONDCOM NEX

ENGLISH



**Accelerating labor
saving in inspections**

NEW Roundness and Cylindrical Profile
Measuring Instruments

RONDCOM NEX

“NEX”t Stage of RONDCOM for further labor

Hassle-free measurement of any workpiece thanks to a rich



A 3-in-1 Machine Satisfying Various Measurement Needs with Functions to Measure Roundness, Diameter, and Roughness, as well as Selectable Specifications

In addition to roundness measurement, RONDCOM NEX offers high-precision diameter measurement with functions common to the series. The NEX Rs/Rs α models are also capable of measuring roughness. Users can choose from various specifications to suit their needs, such as a higher maximum loading mass (30/60 kg), greater column size (300/500/900* mm), and either manual or automatic alignment and detector orientation adjustment. We respond to all of our customers' needs with a diverse range of functions and selectable specifications that makes these machines much more than mere roundness and cylindrical profile measuring instruments.

*Only SD type of NEX α /NEX Rs α



Continuous Measurement of Roundness and Roughness on One Machine Labor-saving option: AFD(Automatic Force adjustment Detector)

The AFD (Automatic Force adjustment Detector) allows automatic adjustment of measurement direction and force in the software. As such, it is possible to automatically measure the outer and inner diameters of a workpiece. When measuring notched workpieces, the front travel can be automatically adjusted to prevent the stylus from dropping. In addition, this AFD and T-stylus option can be mounted on the RONDCOM NEX Rs 300/Rs α 300 for roughness measurement, allowing for automatic switchover and continuous measurement of roundness and roughness. This option helps to save labor as two features can be measured on one machine with no need for operators to place workpieces in two separate measuring machines.



Hassle-free measurement of any workpiece thanks to a rich lineup, myriad of functions, and excellent labor-saving options

Labor-saving option: XY-Axis Automatic Stage

When measuring a large number of workpieces, a typical table rotation roundness and cylindrical profile measuring instrument requires the workpiece to be replaced multiple times between individual measurements. However, the RONDCOM NEX series features a common optional XY-Axis Automatic Stage, allowing many workpieces on the stage to be measured at once without requiring any special setup. This is a labor-saving option that minimizes operator effort and reduces measurement takt time. The labor-saving options can be retrofitted to existing RONDCOM NEX machines to upgrade to labor-saving specification.

saving and minimizing operator interventions

lineup, myriad of functions, and excellent labor-saving options



Versatility

Meeting diverse needs with wide-ranging lineup to choose from



ROND COM NEX 200 DX2-12

Standard model ROND COM NEX

- Max. loading weight: 30kg
- Max. measuring height: 300 / 500 mm
- Alignment: Manual / CNC
- Detector posture change: Manual / CNC
- Type: With integrated measurement and data processing section (DX2)
/ With separate measurement and data processing sections (SD2)
- Alignment can be upgraded from manual to CNC after delivery



ROND COM NEX Rs 200 DX2-12

Model for surface texture measurement ROND COM NEX **Rs**

- Max. loading weight: 30kg
- Max. measuring height: 300 / 500 mm
- Alignment: CNC
- Detector posture change: Manual / CNC
- Type: With integrated measurement and data processing section (DX2)
/ With separate measurement and data processing sections (SD2)
- Capable of measuring surface texture



Measuring height 900 mm Ultra-high column specification
ROND COM NEX α 300 SD2-23



Measuring height 500 mm High column specification
ROND COM NEX Rs α 200 SD2-22

Model for heavy-weight workpieces ROND COM NEX α

- Max. loading weight: 60kg
- Max. measuring height: 300 / 500 / 900* mm
- Alignment: Manual / CNC
- Detector posture change: Manual / CNC
- Type: With integrated measurement and data processing section (DX2)
/ With separate measurement and data processing sections (SD2)

*Applicable only to SD2

Model for surface texture measurement and heavy-weight workpieces ROND COM NEX Rs α

- Max. loading weight: 60kg
- Max. measuring height: 300 / 500 / 900* mm
- Alignment: CNC
- Detector posture change: Manual / CNC
- Type: With integrated measurement and data processing section (DX2)
/ With separate measurement and data processing sections (SD2)
- Capable of measuring surface texture

*Applicable only to SD2

Versatility

Wide-ranging lineup and accessories enabling measurement of various types of workpieces

- NEX
- NEX Rs
- NEX α
- NEX Rs α

Offset detector holder enabling measurement of thick workpieces with no interference

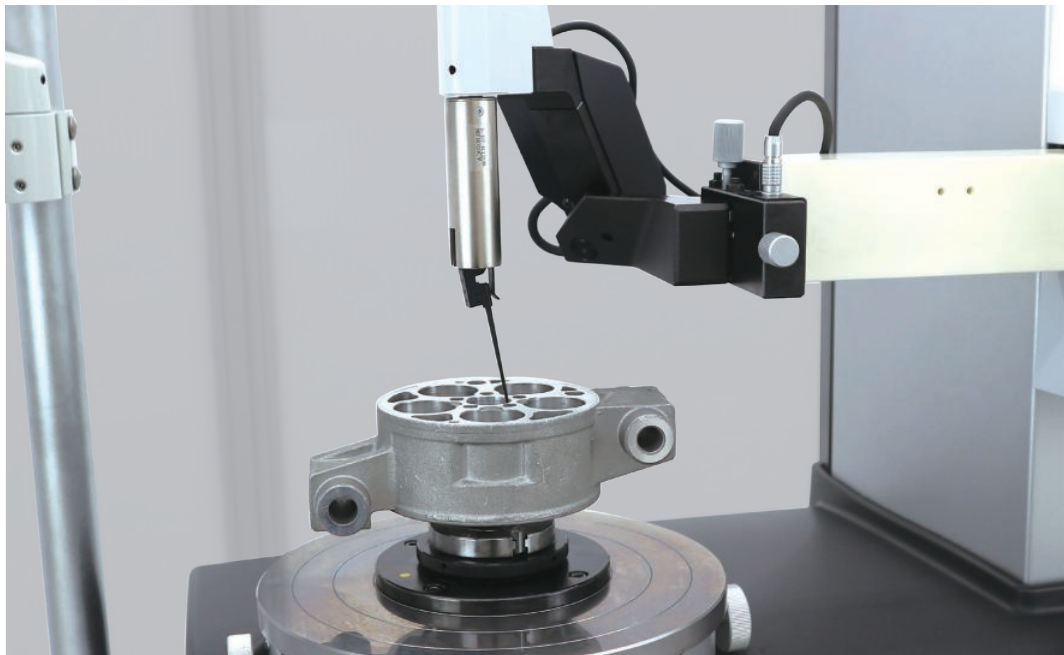

Having a unique mechanism that prevents interference between the R-axis arm and workpiece by offsetting the stylus 80 mm below from the center of the R-axis. Inner diameter of workpieces with flange or thick workpieces, connecting rods, or die cast products can be measured without interference.

Standard accessory for ROND COM NEX 100/200 Manual type

Outer (inner) diameter and upper (lower) surface measurement can be switched over simply by bringing down the holder

Patented

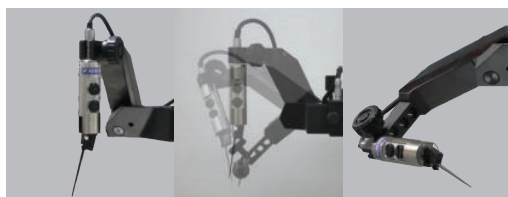

If this offset-type detector holder is brought down, the detector naturally changes its orientation by 90 degrees, thus not requiring manual rotation of the detector.

Standard accessory for ROND COM NEX 300 CNC type

Changes detector posture automatically with software or CNC program

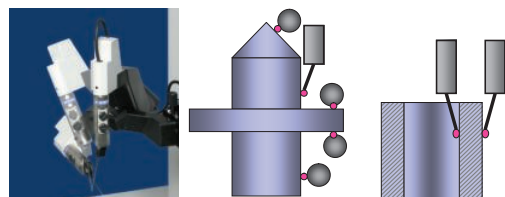

Offset-type CNC detector holder has excellent features of the conventional offset-type detector holder and also can automatically change the posture of the detector. It can automatically control the posture of the detector for inner/outer diameter, or upper/lower or tapered surface, significantly increasing measurement efficiency.

NEX

NEX Rs

NEX α NEX Rs α

For measurement of heavy-weight workpieces Max. loading weight: 60kg

The high-end " α " series is equipped with a different base from RONDCOM NEX and RONDCOM NEX Rs and a dedicated high-rigidity low-vibration air spindle. The maximum loading weight is increased from 30kg to 60kg while maintaining a high measurement accuracy.



NEX

NEX Rs

NEX α NEX Rs α

For measurement of long workpieces Max. measuring height: 900 mm Ultra-high column specification*

The " α " series includes ultra-high column specification models with the maximum measuring height significantly increased from 300/500mm to 900mm. These models are capable of measuring workpieces which conventionally had no choice but to be measured with a large detector-rotating type roundness/cylindrical profile measuring instruments because the height-direction strokes of previous models were insufficient.

*Applicable only to SD2. Optional anti-vibration stand E-VS-R86B/87B is required.



NEX

NEX Rs

NEX α NEX Rs α

For measurement of large-diameter workpieces Measuring diameter extending offset detector holder* which extends the maximum measuring diameter by \varnothing 50 mm

Detector holder enabling extension of measuring diameter is available as a dedicated optional accessory. When this holder is used, the maximum measuring diameter increases by \varnothing 50 mm compared with the use of ordinary detector holders. (Outer diameter \varnothing 350 mm, inner diameter \varnothing 410 mm)

*Optional accessory for RONDCOM NEX 100/200. The offset from the R-axis center is 70mm, while that of an ordinary offset detector is 80mm.

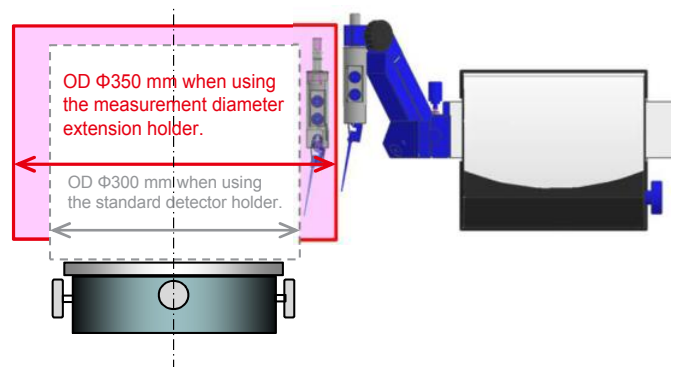

NEX

NEX Rs

NEX α NEX Rs α

For measurement of workpieces with small holes Crank stylus

Patented

In such cases where the inner diameter of a small hole is measured after measuring the outer diameter of a workpiece, while the stylus is kept at the same angle as in the outer diameter measurement, the stylus and the workpiece may interfere with each other. The crank stylus enables continuous measurement of the outer diameter of workpieces and the inner diameter of small holes without the need for stylus angle adjustment to avoid interference.

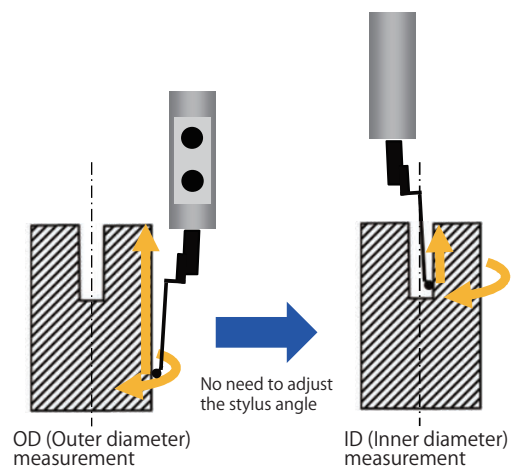

Multifunctional

Diverse measurement functions that go beyond the conventional roundness/cylindrical profile measuring instruments

NEX | NEX Rs | NEX α | NEX Rs α

Measurement of inner and outer diameters with high repeatability

Opposed Diameter Measurement Function Patented

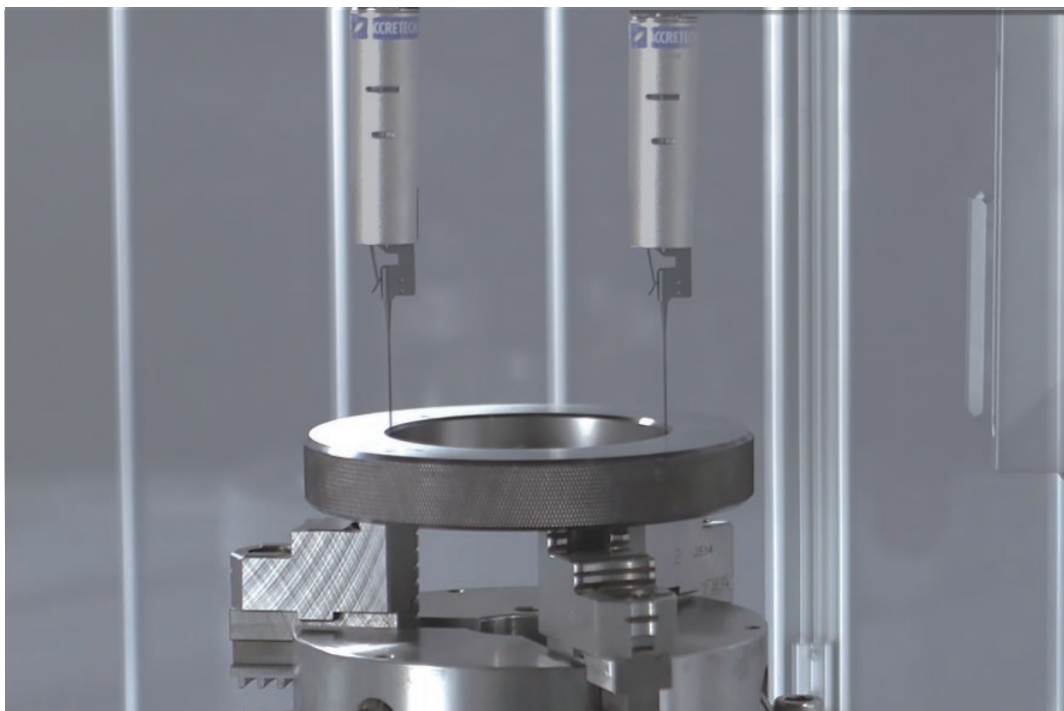

To measure the diameter of a workpiece with a general roundness/cylindrical profile measuring instrument, measurement is taken by applying the stylus to the workpiece from one side and the radius value thus obtained is doubled to determine the diameter. However, if a deviation occurs in the relative positions of the measuring machine and the workpiece due to temperature changes, the deviation is reflected on the diameter value. Accordingly, it is impossible to perform measurement with high repeatability, even if a highly accurate scale is mounted. In opposing diameter measurement function, which is a standard feature of RONDCOM NEX series, a workpiece is measured at the 0 degree and opposing 180 degree positions of the table, respectively. The evaluation algorithm implemented as the standard to correct the errors by temperature change and generatrix line shifting, performs highly-precise diameter measurement.

Measurable diameter

- With standard holder : \varnothing 30 mm or less
- With opposed diameter measuring holder (optional) : \varnothing 100 mm or less

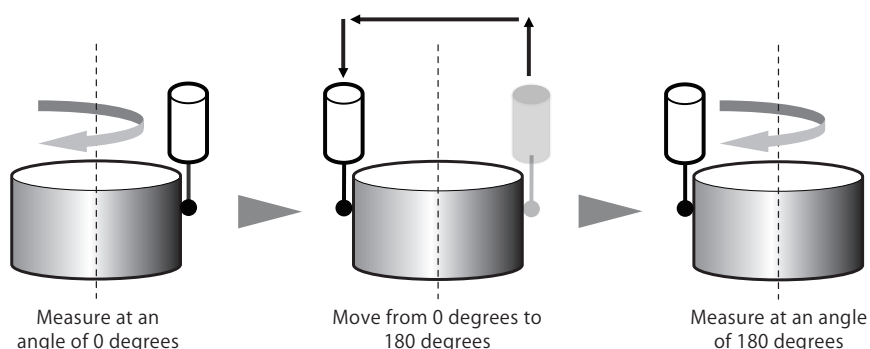

NEX

NEX Rs

NEX α

NEX Rs α

Roughness measurement compliant with JIS/ISO standard

By simply changing to the surface texture measurement detector, it can perform surface texture measurement in the axis, radial and rotational directions along the applicable axis at high accuracy per ISO/JIS requirements. Since measurement can be performed at a speed reduced to almost the same level as commonly used surface texture measuring instruments, bouncing of the stylus is suppressed so that measurement results with less noise can be obtained.

Measurement example: R-axis linear motion roughness measurement (roughness standard specimen)

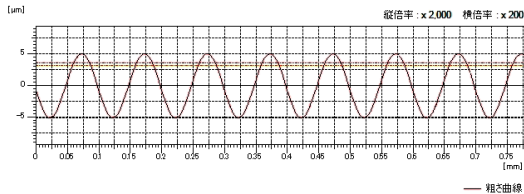

Effortless roughness measurement in Z-, R- and T-axis directions

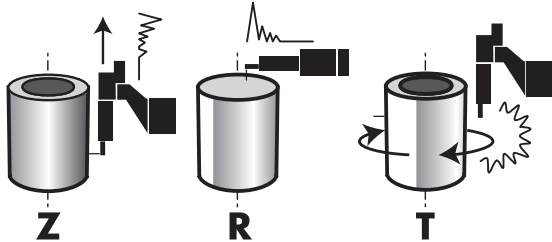

Using the auto-aligning function in roundness measurement saves the time required for ridging in roughness measurement in the Z-axis direction. Moreover, using RONDCOM NEX 300 equipped with a CNC detector holder capable of changing the detector posture automatically, the roughness in the T-axis (circumference) direction and the end face roughness can be measured continuously.

Lead-twist Measurement Option

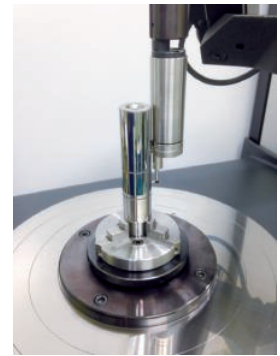
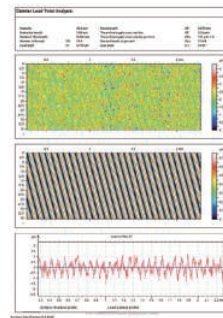

Measure the periodic and fine twist structure on a cylindrical shaft. Visualization of twist structure enables easy analysis.

*SURFCOM Map comes with the machine as analytical software.

NEX

NEX Rs

NEX α

NEX Rs α

R-axis Following Measurement Function

It is a function to measure linearly while the R-axis follows the shape of the workpiece to be measured. Taper angle* can be measured even if it exceeds the range of the detector.

*Taper angle may have an impact on the measurement accuracy. Contact us for details.

Comparison with high-accuracy contour measuring machine for taper angle measurement

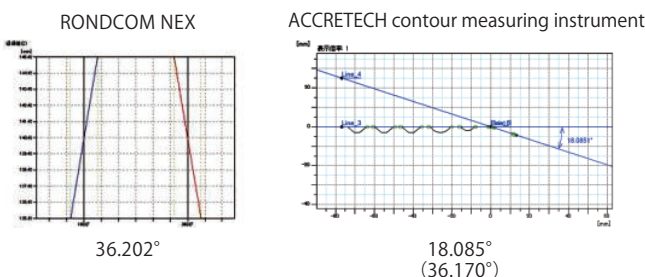

Labor saving

Excellent labor-saving options reducing operator interventions to achieve higher efficiency in measurement

NEX

NEX Rs

NEX α

NEX Rs α

AFD (Automatic force adjustment detector)*¹ enabling automatic switching of roundness and surface texture measurement*², and inner/outer diameter measurement

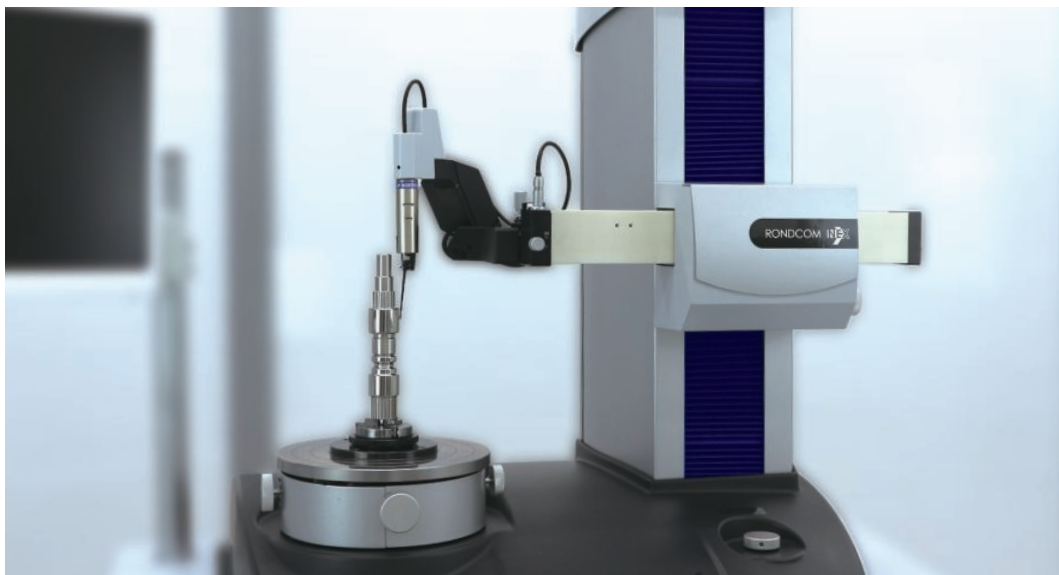

The previous detector required manual adjustment of measuring directions, measuring Forces and front/over travel by using front knob, but the AFD enables automatic adjustment of these on the software.

*¹ Optional accessory for ROND COM NEX 200 / 300

*² ROND COM NEX Rs/ NEX Rs α only

Automatic adjustment of front travel



Limiting the front travel (fall of the stylus) on the software enables safe and smooth measurement of notched workpieces, preventing the stylus from being caught by the notched side wall.

Continuous roundness/roughness measurement*

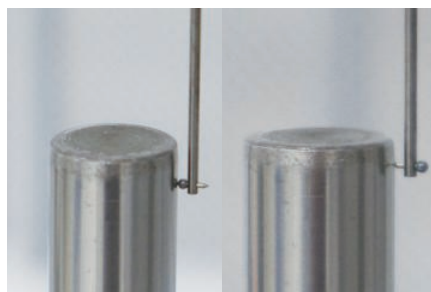

The automatic force adjustment function combined with T-stylus option enables continuous measurement of roundness and roughness without changing the detector or the stylus.

Continuous automatic measurement of inner and outer diameters with a manual type detector holder

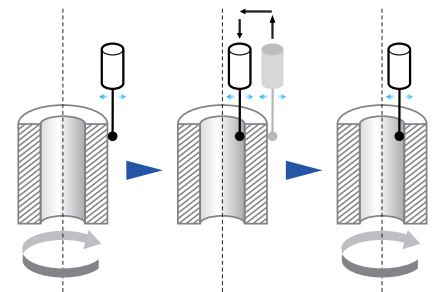

Conventionally, in order to measure the inner and outer diameters with a machine equipped with a manual type detector holder, it was necessary to manually rotate the detector in the horizontal direction. With AFD, the inner and outer diameters can be measured continuously and automatically without changing the orientation of the detector.

* ROND COM NEX Rs/ NEX Rs α only

NEX	NEX Rs	NEX α	NEX Rs α
-----	--------	--------------	-----------------

Capable of measuring multiple locations and workpieces without setup change
XY-Axis Automatic Stage Patented



Continuous measurement of multiple workpieces/locations saves the trouble of changeover, achieving reductions in time and labor required for measurement. Data of different evaluation items such as roundness and cylindricity as well as surface roughness, lead and twist (by attaching on RONDCOM NEX Rs/NEX Rs α series) can be automatically captured at once for multiple workpieces. The supplied counterweight offsets eccentric loads during the table feeding and realizes a highly accurate measurement in a wide range of stroke.

Continuous measurement of multiple workpieces / locations with no changeover

Can be freely attached, removed, and capable of being retrofitted

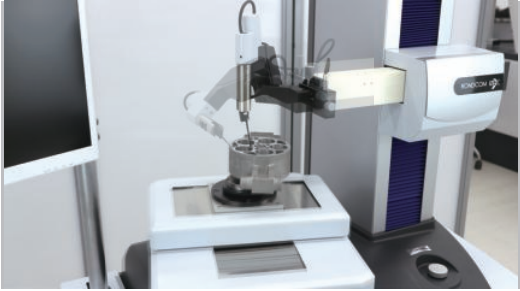

◀ Video of the measurement operation is available.

Since it can be attached and removed by customer, customer can choose between the standard table and the XY-axis automatic stage depending on the workpiece. As this option is available for retrofitting, it can be attached to an existing machine*.

*By modifying part of the table of the measuring machine at the site.

Maintainability

User-friendly design common to the series,
minimizing maintenance effort to enable an effective use of time

Automatic oiling mechanism making it sufficient to supply oil to the column once a year*²

An oil tank and an automatic oiling mechanism are built into the Z-axis column. While a general roundness/cylindrical profile measuring machine requires periodic oiling of the column, no manual oiling is necessary for RONDCOM NEX as the internal mechanism of the column is automatically oiled*¹. All the operator needs to do is to fill the built-in oil tank once a year *².

*1 The timing of automatic oiling can be customized on the software according to the usage status of the machine.

*2 The oiling frequency is for reference only. The actual frequency may change according to the usage status of the machine.



Stainless steel rotary table that makes oiling and use of anti-corrosion paper unnecessary

The rotary table of RONDCOM NEX is made of stainless steel. It can be used effortlessly with no daily maintenance such as oiling and covering with anti-corrosion paper after use.

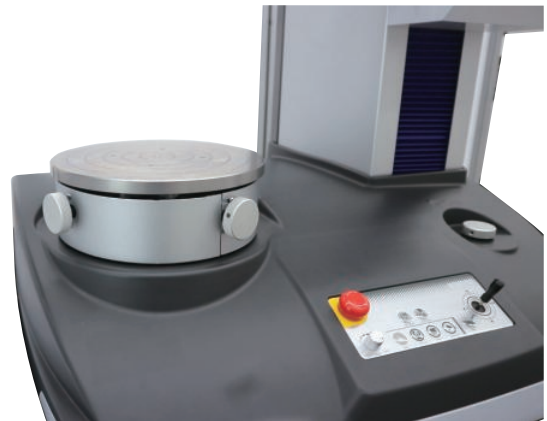

Ceramic R-axis arm requiring no daily oiling and hardly affected by temperature changes

The R-axis arm, which is made of ceramic, is low-maintenance as it does not require daily oiling to prevent corrosion. Also, because of its low thermal expansion coefficient, the impact of room temperature changes on the accuracy can be minimized.



Hardware

Item	Model	RONDCOM NEX (-11, -12)																			
		RONDCOM NEX α (-21,-22, -23)																			
		100						200				300									
		SD2		DX2		SD2		DX2		SD2		DX2									
Model*1		11	12	21	22	23	11	12	21	22	23	11	12	21	22	23	11	12	21	22	23
Alignment		Manual						CNC													
Changing the posture of detector		Manual						Manual				CNC									
Measuring range	Max. measuring diameter (mm)	O.D. : \varnothing 300 (\varnothing 350)*4										O.D. : \varnothing 300									
		I.D. : \varnothing 360 (\varnothing 410)*4										I.D. : \varnothing 360									
	Radial feed range (R-axis) (mm)	180						180													
	Up/down feed range (Z-axis) (mm)	300	500	900	300	500	300	500	900	300	500	300	500	900	300	500					
	Max. loading diameter (mm)	\varnothing 580						\varnothing 580													
	Max. measuring height (mm)	300	500	900	300	500	300	500	900	300	500	300	500	900	300	500					
Depth of measurement (mm)	150 *2																				
Accuracy	Rotation accuracy *3	Radial direction (μ m)	(0.02+3.2H/10000)																		
		Axis direction (μ m)	(0.02+3.2R/10000)																		
	Straightness accuracy	Up/down direction (Z-axis) (μ m/mm)	0.10/100	0.20/100	0.10/100	0.10/100	0.20/100	0.10/100	0.10/100	0.20/100	0.10/100	0.10/100	0.20/100	0.10/100	0.10/100	0.20/100					
		Radial direction (R-axis) (μ m/mm)	0.7/180																		
	Parallelism accuracy	Z-axis/T-axis (μ m/mm)	0.7/300	1.0/500	2.0/900	0.7/300	1.0/500	0.7/300	1.0/500	2.0/900	0.7/300	1.0/500	0.7/300	1.0/500	2.0/900	0.7/300	1.0/500				
	Squareness accuracy	R-axis/T-axis (μ m/mm)	1.0/150																		
	Scale indication accuracy	R-axis (μ m)	(0.5+L/180+2L Δ T/100)																		
		L: Moving length (mm) Δ T: The difference in temperature between 20°C and the current temperature (°C)																			
Speed	Measurement speed	Rotation speed (θ -axis) (/min)	1 ~ 10						1 to 10												
		Up/down speed (Z-axis) (mm/s)	0.5 ~ 10						0.5 to 10												
		Radial direction speed (R-axis) (mm/s)	0.5 ~ 10						0.1 to 1.5 (at roughness measurement: only with NEX Rs/NEX Rs α)												
	Drive speed	Rotation speed (θ -axis) (/min)	Max. 20																		
		Up/down speed (Z-axis) (mm/s)	5 to 60																		
		Radial direction speed (R-axis) (mm/s)	5 to 30																		
Table	Table diameter (mm)	\varnothing 235																			
	Centering range (mm)	\pm 5																			
	Tilting range (°)	\pm 1																			
	Max. loading weight	NEX/NEX Rs (kg)	30																		
NEX α /NEX Rs α (kg)		60																			
Detector /Stylus	For roundness measurement (standard accessory common to the R-NEX series)	Detector E-DT-R120B	Measurement force (mN)	30 to 100																	
			Linear range (μ m)	\pm 1000																	
		Stylus EM46000-S302	Function	O.D./I.D. switching function, front/overtravel adjustment function, emergency stop function																	
			Tip shape (mm)	\varnothing 1.6																	
	For both roundness and roughness measurement (standard accessory for NEX Rs /NES Rs α)	Low measuring force detector E-DT-R168D	Length (mm)	53																	
			Tip material	Cemented carbide																	
		Stylus (for 010 2505)	Measurement force (mN)	4																	
			Linear range (μ m)	\pm 400																	
		Stylus (for 010 2501)	Tip shape (mm)	\varnothing 1.6																	
			Length (mm)	26.5																	
	For high-accuracy roughness measurement (option for NEX Rs/NEX Rs α)	Detector E-DT-R290B	Tip material	Ruby																	
			Measurement force (mN)	Rtip 5 μ m (90° cone)																	
	Stylus DM43801	Length (mm)	26.5																		
		Tip material	Diamond																		
Detector E-DT-R290B	Measurement force (mN)	0.75																			
	Linear range (μ m)	\pm 500																			
Stylus DM43801	Tip shape (mm)	Rtip 2 μ m (60° cone)																			
	Tip material	Diamond																			

*1 NEX-11/NEX Rs-11(Max. loading weight 30 kg, 300 mm column), NEX-12/NEX Rs-12(Max. loading weight 30 kg, 500 mm column)
 NEX α -21/NEX Rs α -21(Max. loading weight 60 kg, 300 mm column), NEX α -22/NEX Rs α -22(Max. loading weight 60 kg, 500 mm column), NEX α -23/NEX Rs α -23(Max. loading weight 60 kg, 900 mm column)

*2 Please contact our sale personnel as there may be limitations due to the measurement diameter, and the combination of detector and stylus.

*3 JIS B 7451-1997 compliant. H is the height of the measurement point from the upper surface of the table in mm, and R is the distance from the rotational center of the table in mm.

*4 When using measurement diameter extension offset-type detector holder E-DH-RB86A (optional)

● Software

Item	Model	RONDCOM NEX (-11, -12) RONDCOM NEX α (-21,-22, -23)														
		100						200				300				
		SD2		DX2		SD2		DX2		SD2		DX2				
Model*1		11	12	21	22	11	12	21	22	11	12	21	22	11	12	
		21	22	23	21	22	21	22	23	21	22	21	22	23	21	22
Number of sampling	(point)	14400														
Type of filter	Digital filter	Gaussian/2RC/spline/robust (spline)														
Cutoff value	Rotational direction (θ-axis)	selectable any value in 15, 50, 150, 500, 1500 UPR, 15 to 1500 UPR														
	Rectilinear direction (Z-axis)	1 to 1500 UPR														
Roundness evaluation of form error		0.025, 0.08, 0.25, 0.8, 2.5, 8 mm (any value in 0.0001 mm)														
Measuring items	Rotational direction	MZC (min. zone circle method), LSC (least square circle method), MIC (max. inscribed circle method), MCC (min. circumscribed circle method), N.C. (no compensation)														
	Rectilinear direction	Roundness, flatness, flatness (compound), parallelism, concentricity, coaxiality, cylindricity, diameter deviation, squareness, thickness variation, partial circle														
Roughness analysis item (RONDCOM NEX Rs /NEX Rs α only)	Standard	Straightness (Z), straightness (R), cylindricity, squareness, parallelism, diameter deviation, axis straightness														
	Parameter	JIS-2013、JIS-2001、JIS-1994、JIS-1982、ISO-2009、ISO-1997、ISO-1984、DIN-1990、ASME-2002、ASME-1995														
	Evaluation curve	Ra, Rq, Ry, Rp, Rv, Rc, Rz, Rmax, Rt, RzJ, R3z, Sm, S, R Δ a, R Δ q, R λ a, R λ q, TILT A, Ir, Pt, Pc, Rsk, Rku, Rk, Rpk, Rvk, Mr1, Mr2, VO, K, tp, Rmr, tp2, Rmr2, R δ c, AVH, Hmax, Hmin, AREA, NCRX, R, Rx, AR, NR, CPM, SR, SAR														
	Characteristic graph	Profile curve, roughness curve, filtered waviness curve, rolling circle waviness curve, rolling circle center line waviness curve, ISO13565-1 profile curve, ISO13565-1 roughness curve, roughness motif curve, waviness motif curve, envelope waviness curve														
	Tilting adjustment methods	Bearing area curve, amplitude distribution graph, power spectrum curve														
Analysis processing functions		Least square straight line correction, n-dimension polynomial correction, both ends correction, least square circle correction, least square oval correction, spline correction, robust (spline) correction, spline curve correction														
		Notch function (level, angle, cursor), combination of roundness evaluation methods, nominal value collation, cylinder 3D profile display (line drawing, shading, contour line), real-time display, profile characteristic graph display (bearing area curve, amplitude distribution function, power spectrum), CNC automatic measuring function														
Display item		Notch function (level, angle, cursor), combination of roundness evaluation methods, nominal value collation, cylinder 3D profile display (line drawing, shading, contour line), real-time display, profile characteristic graph display (bearing area curve, amplitude distribution function, power spectrum), CNC automatic measuring function, automatic centering/tilting adjustment function														
		Measuring conditions, measuring parameters, comments, printer output conditions, profile graphics (expansion plan, 3D plan), error messages, etc.														

● Dimensions and other items

Installation dimension*5	Width	(mm)	720	1074	1400	720	1074	1400	720	1074	1400				
	Depth	(mm)	580	824	820	580	824	820	580	824	820				
	Height	NEX	(mm)	925	1125	1595	1795	925	1125	1595	1795	925	1125	1595	1795
		NEX Rs	(mm)	925 1125 2125 1595 1795 925 1125 2125 1595 1795 925 1125 2125 1595 1795											
NEX α / NEX Rs α		(mm)	925 1125 2125 1595 1795 925 1125 2125 1595 1795 925 1125 2125 1595 1795												
Weight*5	NEX/NEX Rs	Measuring unit	(kg)	Approx.170	Approx.180	Approx.330	Approx.340	Approx.170	Approx.180	Approx.330	Approx.340	Approx.170	Approx.180	Approx.330	Approx.340
		Data processor	(kg)	Approx.10		Approx.10		Approx.10		Approx.10		Approx.10		Approx.10	
	NEX α / NEX Rs α	Measuring unit	(kg)	Approx.190	Approx.200	Approx.350	Approx.360	Approx.190	Approx.200	Approx.350	Approx.360	Approx.190	Approx.200	Approx.350	Approx.360
		Data processor	(kg)	Approx.10		Approx.10		Approx.10		Approx.10		Approx.10		Approx.10	
Power supply	Voltage, frequency	(V, Hz)	AC100 to 240, 50/60 (grounding required)												
	Power consumption	(VA)	Approx.630												
Air supply	Supply air pressure	NEX	(MPa)	0.35 ~ 0.7	0.35 ~ 0.7	0.35 ~ 0.7	0.35 ~ 0.7	0.35 ~ 0.7	0.35 ~ 0.7	0.35 ~ 0.7	0.35 ~ 0.7				
		NEX α / NEX Rs/NEX Rs α	(MPa)	0.45 ~ 0.7											
	Workin air pressure	NEX	(MPa)	0.3	0.3	0.3	0.3	0.3	0.3	0.3	0.3				
		NEX α / NEX Rs/NEX Rs α	(MPa)	0.4											
	Air consumption volume	NEX	(NL/min)	30	30	30	30	30	30	30	30				
		NEX Rs/NEX Rs α	(NL/min)	40											
Air supply connecting nipple (main unit)			One-touch pipe joint for outer diameter Φ 8 mm hose												
Operation environment	Operation temperature	(°C)	10 to 30												
	Guaranteed accuracy temperature range	(°C)	20 ± 2												

*5 The installation dimensions and weight of NEX α -23/NEX Rs α (Max. loading weight 60 kg, 900 mm column) are the values when using the anti-vibration table E-VS-R86B (optional).

External view

DX2

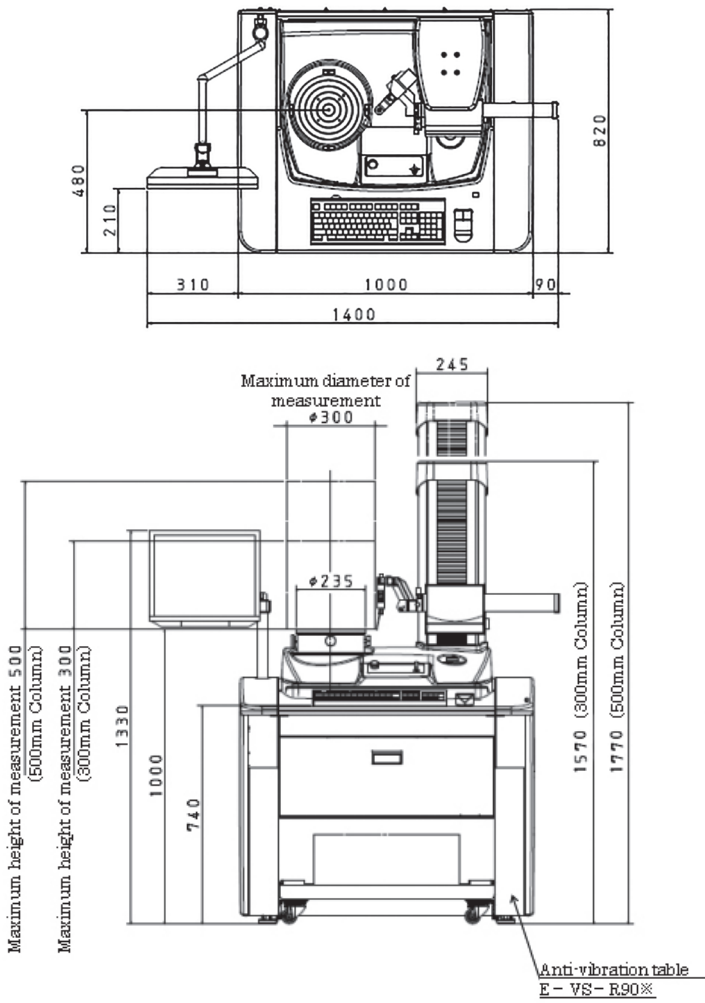

SD2 Z = 300 / 500

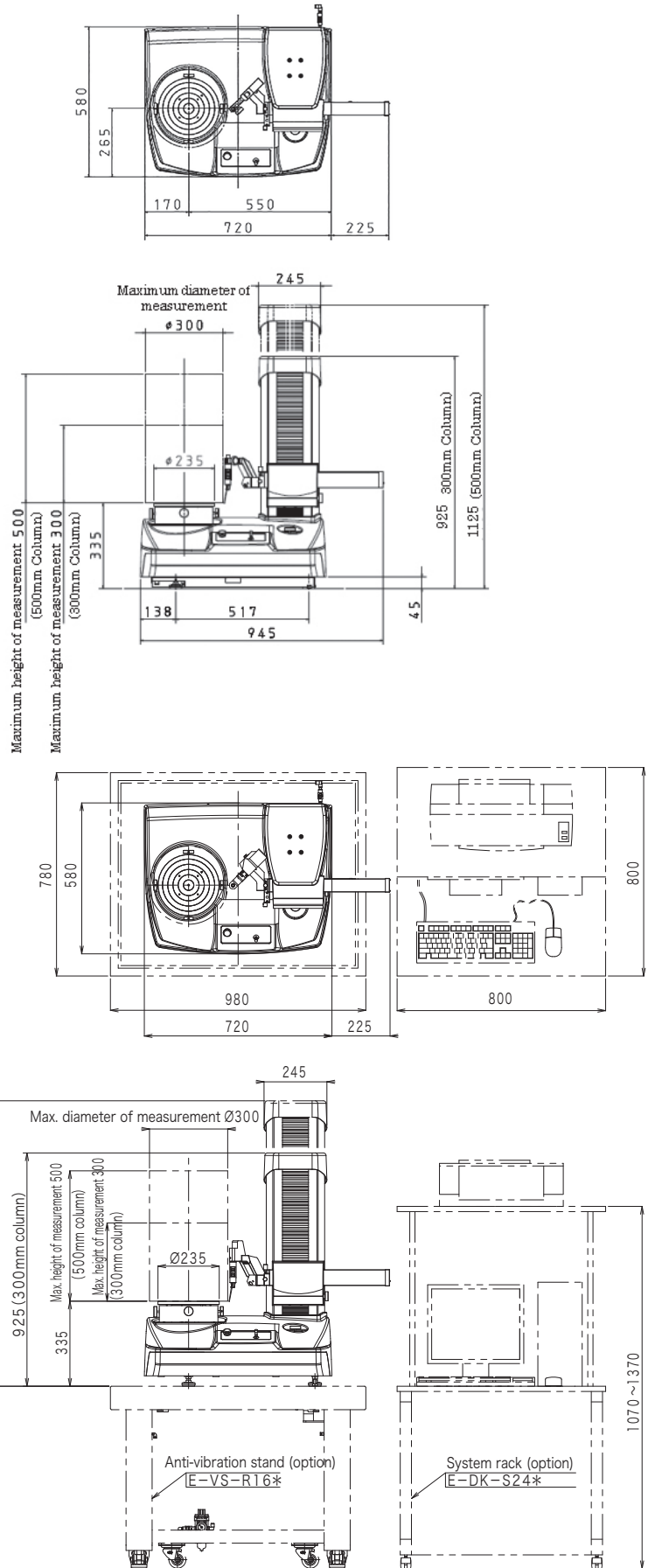

SD2 Z = 900

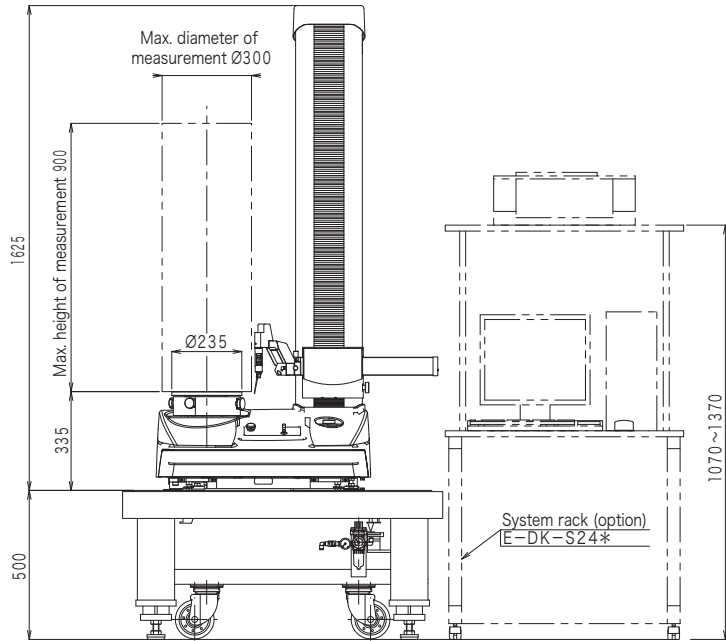
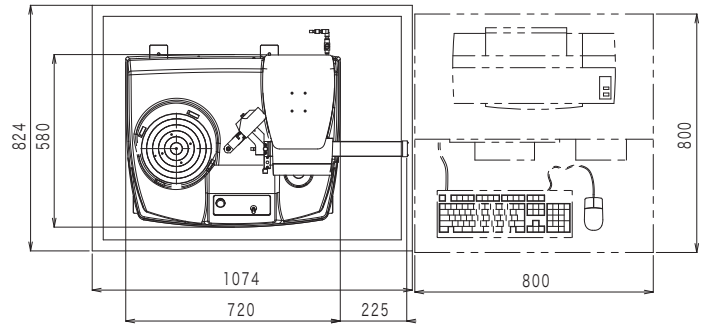
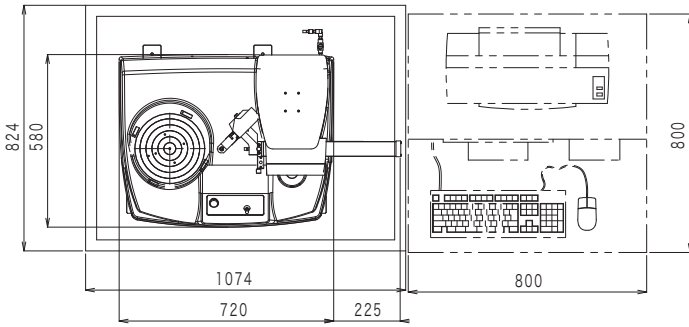

With Anti-vibration stand E-VS-R86B

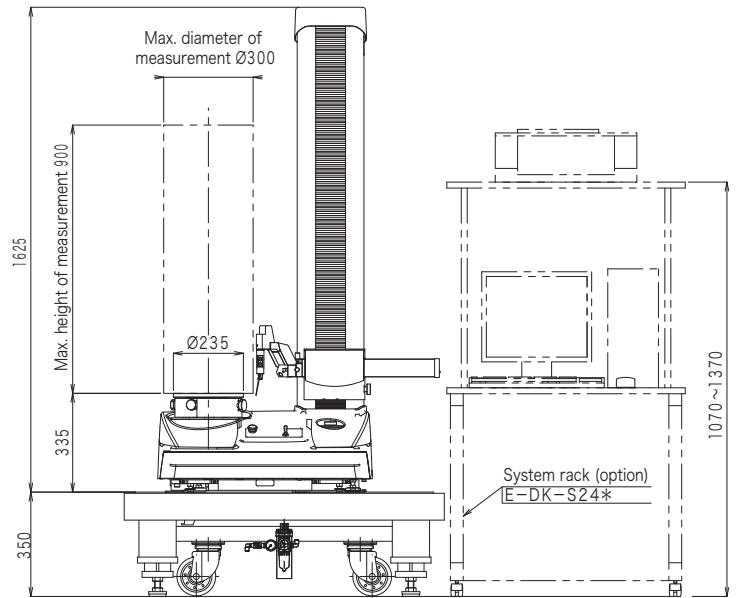

With Anti-vibration stand E-VS-R87B

Names of models based on system configuration and selection

Product name **RONDCOM NEX / NEX Rs**
RONDCOM NEX α / NEX Rs α

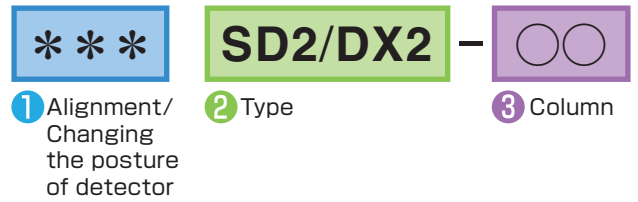

1 Selection method of alignment and changing the posture of the detector

Item	Manual /CNC	100*	200	300
Alignment	Manual	●		
	CNC		●	●
Changing the posture of detector	Manual	●	●	
	CNC			●

*RONDCOM NEX / NEX α only

2 Type selection

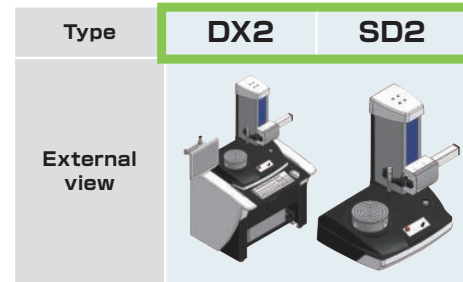

3 Column selection

RONDCOM NEX / NEX Rs

Column	11	12
Up/down stroke	300mm	500mm

RONDCOM NEX α / NEX Rs α

Column	21	22	23
Up/down stroke	300mm	500mm	900mm (Only SD)

"On-the-spot" upgrading to CNC machine after delivery*

RONDCOM NEX 100, which is a manual model, can be upgraded to RONDCOM NEX 200 or 300, which is a CNC model, after delivery. Customers who introduced a manual model due to low measurement demands or other reasons may upgrade it to CNC as necessary to achieve labor saving in inspection.

*RONDCOM NEX α is excluded.

● Conventional measuring instrument



● RONDCOM NEX 100 and NEX 200/300 series

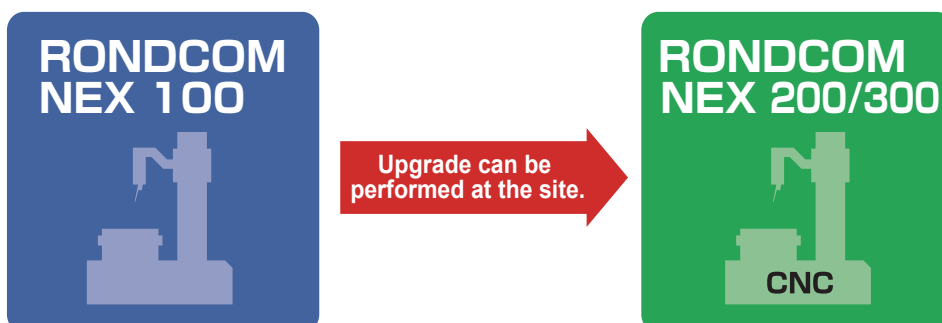

■ AFD(Automatic Force adjustment Detector)

Item	AFD (Automatic Force adjustment Detector)	
Linear range	(μm)	± 1000
Measuring force*	(mN)	4 ~ 30 (controlled by software ACCTee)
Function	O.D./I.D. switching function(controlled by ACCTee) Front/overtravel adjustment function(controlled by ACCTee) Emergency stop function	
Remark	Option for 200/300 system	

*Measuring force range is determined by the mass and angle of the mounted stylus.
Contact us for inquiries on the compatible styli.

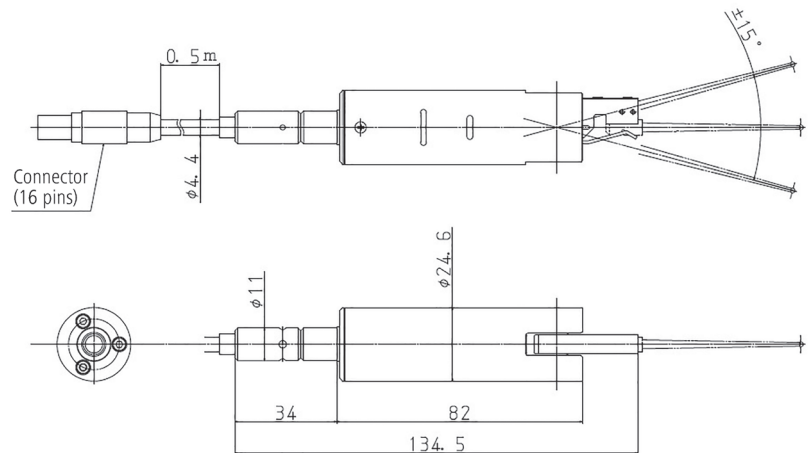

■ XY-axis automated stage

ITEM		Specifications of RONDCOM NEX series with XY-axis automatic stage	
Drive range	Cx-axis	(mm)	200 (± 100)
	Cy-axis	(mm)	100 (± 50)
Workpiece	Loadable range	(mm)	$\Phi 300$ from the center of XY-axis automatic stage's table
	Max. loadable weight	(kg)	5
Drive speed of the table		(mm/s)	Max. 20
Rotational Accuracy *	Radial direction	(μm)	$(0.08 + 6H / 10000)$
	Axial direction	(μm)	$(0.08 + 6R / 10000)$
Accuracy guarantee range *		(mm)	$120 \leq H \leq 300$
Z-axis Parallelism		($\mu\text{m}/\text{mm}$)	0.5 / 150
Installation dimensions and weight	Width x Depth x Height		(mm) 540 x 356 x 132
	Height from the upper surface of the machine's table to the upper surface of XY-axis automatic stage's table	(mm)	120
	Weight	(kg)	Approx. 20 (except for the standard equipped counterweights)
Applicable model		RONDCOM NEX / NEX α 200 • 300 RONDCOM NEX Rs / NEX Rs α 200 • 300	

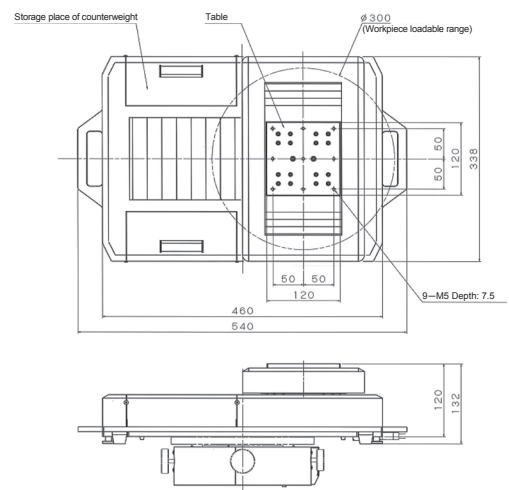

* JIS B 7451-1997 compliant. H is the height of the measurement point from the upper surface of the machine's table in mm, R is the distance from the rotational center of the machine's table in mm

• The other specification items conform to the Specifications of RONDCOM NEX series

Other main accessories

For information on the accessories not included in the following pages, please refer to the collective catalogue of Roundness and Cylindrical Profile and Measuring Instruments of Tokyo Seimitsu Co., Ltd.



Accessories for DX2 type

Back Cover

The back cover prevents dust invasion into the base.

Accessories for SD2 type

Name	Model	External view	Specifications	Remarks
Anti-vibration table (H: 700)	E-VS-R16E		Anti-vibration system: Diaphragm air spring Natural frequency: V = 2 Hz, H = 2.2 Hz Load weight: 260 kg Air Source: 0.45 MPa to 0.7 MPa	Applicable models: R-NEX, R-NEX Rs, R-NEX α, R-NEX Rs α Dimensions: 980mm (W) x 780 mm (D) x 700 mm (H) 760 mm (W1) x 560 mm (D1) Weight: 200 kg
	E-VS-S286B		Anti-vibration system: Diaphragm air spring Natural frequency: V = 1.6 Hz, H = 2 Hz Load weight: 550 kg Air Source: 0.45 MPa to 0.7 MPa	Applicable models: R-NEX α, R-NEX Rs α Dimensions: 1074 mm (W) x 824 mm (D) x 700 mm (H) 850 mm (W1) x 560 mm (D1) Weight: 340 kg
Anti-vibration table	E-VS-R86B		Anti-vibration system: Diaphragm air spring Natural frequency: V = 1.5 Hz, H = 2 Hz Load weight: 550 kg Air Source: 0.35 MPa to 0.7 MPa	Applicable models: R-NEX α / R-NEX Rs α SD-23 Dimension: 1074 mm (W) x 824 mm (D) x 500 mm (H) 850 mm (W1) x 620 mm (D1) Weight: 340 kg
Anti-vibration table	E-VS-R86B		Anti-vibration system: Diaphragm air spring Natural frequency: V = 1.5 Hz, H = 2 Hz Load weight: 550 kg Air Source: 0.35 MPa to 0.7 MPa	Applicable models: R-NEX α / R-NEX Rs α SD-23 Dimension: 1074 mm (W) x 824 mm (D) x 350 mm (H) 775 mm (W1) x 545 mm (D1) Weight: 400 kg
System rack	E-DK-S24A			Dimensions: 800 mm (W) x 800 mm (D) x (1070 mm to 1370 mm) (H) Weight: 44.5 kg RoHS non-compliant
	E-DK-S25A			Dimensions: 1200 mm (W) x 800 mm (D) x (1070 mm to 1370 mm) (H) RoHS non-compliant

Standard Inventory Parts

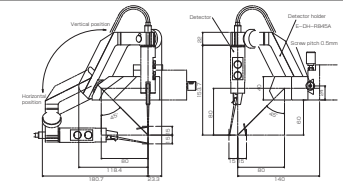
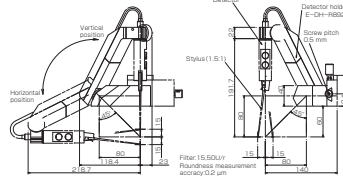
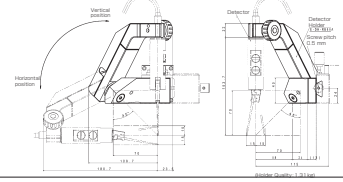
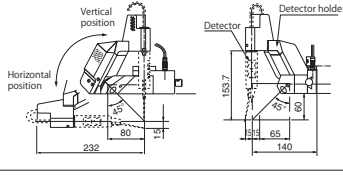
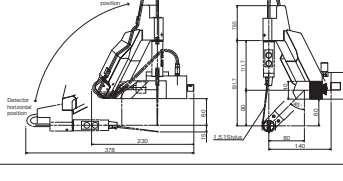

Detector Holders

Name	Model	External view	Specifications
Offset detector holder	E-DH-R845A		RONDCOM NEX/NEX α 100, 200 RONDCOM NEX Rs/NEX Rs α 200 (standard accessory) Throat height H: 153 mm Throat depth D: 65 mm
Offset detector holder 1.5:1 Type	E-DH-R892A		RONDCOM NEX/NEX α 100, 200 RONDCOM NEX Rs/NEX Rs α 200 system use Throat height H: 191 mm Throat depth D: 65 mm Stylus sensitivity: 1.5:1
Measurement diameter extension offset-type detector holder	E-DH-RB86A		RONDCOM NEX/NEX α 100, 200 RONDCOM NEX Rs/NEX Rs α 200 system use Throat height H: 153 mm Throat depth D: 55 mm
Offset CNC detector holder	E-DH-RB28C		RONDCOM NEX/NEX α 300 RONDCOM NEX Rs/NEX Rs α 300 (standard accessory) Throat height H: 153 mm Throat depth D: 65 mm
Offset CNC detector holder 1.5:1 Type	E-DH-RB30B		RONDCOM NEX/NEX α 300 RONDCOM NEX Rs/NEX Rs α 300 system use Throat height H: 191 mm Throat depth D: 65 mm Stylus sensitivity: 1.5:1
Cross feed joint	E-DH-RB08A		RONDCOM NEX/NEX α, NEX Rs/NEX Rs α common use

Detector

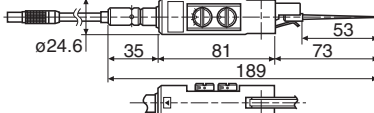
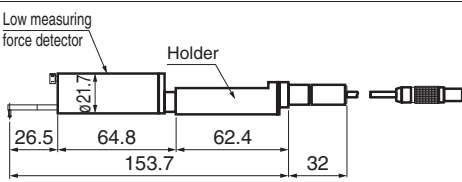
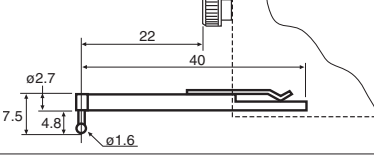
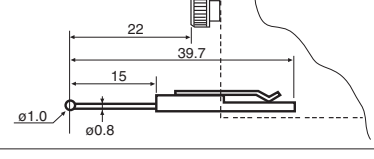
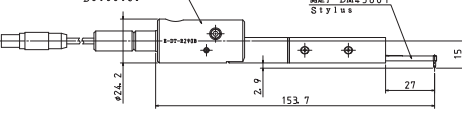
Name	Model	External view	Specifications	Remarks
General purpose detector	E-DT-R120B		Measuring range: ±1000 μm Measuring force: 30 mN to 100 mN Front adjustment mechanism ID/OD switch function	standard accessory common to the R-NEX series
Low measuring force detector	EE-DT-R168D		Measuring range: ±400 μm Measuring force: 5 mN	R-NEX Rs/NEX Rs α : standard accessory
General purpose stylus for low measuring force detector	010 2505			Stylus: Φ 1.6 mm ruby ball
Small hole stylus for low measuring force detector	010 2516			Stylus: Φ 1 mm ruby ball
Detector for surface roughness measurement	E-DT-R290B		Measuring range: ±500 μm Measuring force: 0.75 mN	Applicable models: R-NEX/NEX α, R-NEX Rs/NEX Rs α,

Stylus

1.5:1 Sensitivity L = 97 mm			
Measuring application	Model	External view	Specifications
General purpose	EM46100-S300		Φ 3.2 mm Carbide ball
Small holes	EM46100-S301		Φ 1 mm Carbide ball
General purpose	EM46100-S302		Φ 1.6 mm Carbide ball
Grooves	EM46100-S303		R0.25 mm, 55° conical Sapphire, L-type, L = 4.5 mm
Deep grooves	EM46100-S304		R0.25 mm, 55° conical Sapphire, L-type, L = 10 mm
Corners	EM46100-S305		R0.25 mm, 55° conical Sapphire, L-type, L = 3.4 mm/60°
Grooves	EM46100-S306		R0.25 mm, 55° conical Sapphire, T-type, L = 6.5 mm
	EM46100-S307		R0.25 mm, 55° conical Sapphire, T-type, L = 10 mm
Deep grooves	EM46100-S308		R0.25 mm, 55° conical Sapphire, T-type, L = 20 mm
Extra small holes	EM46100-S309		Φ 0.5 mm Carbide ball
Cutter mark removal	EM46100-S310		R0.25 mm Sapphire, L type, L = 4.8 mm/R15 mm
Stylus attachment	EM-59103-S001		Used when 2: 1 stylus for detectors [E-DT-R32B/E-DT-R74B] is mounted on detectors [E-DT-R120B]

Calibrators

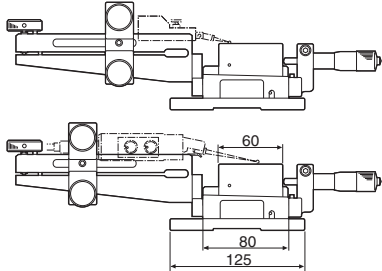
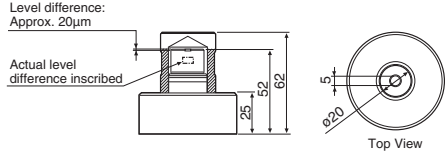
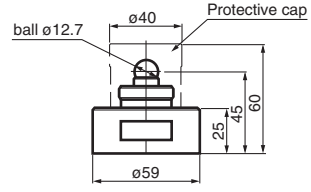
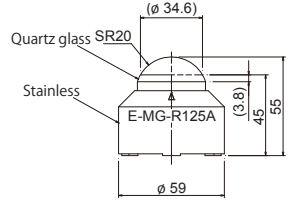
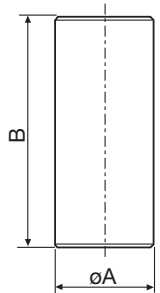
Name	Model	External view	Specifications	Remarks
Magnification calibration set	E-MC-R33A		Max. calibration range: 400 μm Min. scale interval: 0.2 μm Weight: 1.7 kg	
Magnification calibration master	E-MC-R28A	 <p>Level difference: Approx. 20μm</p> <p>Actual level difference inscribed</p> <p>Top View</p>	Level difference: Approx. 20 μm	
Master ball	E-MG-R134A	 <p>ball $\phi 12.7$</p> <p>$\phi 40$</p> <p>Protective cap</p> <p>25</p> <p>45</p> <p>60</p> <p>$\phi 59$</p>	Sphericity: 0.05 μm Material: Chrome bearing steel	R-NEX/NEX α 200/300, R-NEX Rs/NEX Rs α : standard accessory
	E-MG-R135A			Provided with wooden box.
	E-MG-R125A	 <p>Quartz glass SR20</p> <p>Stainless</p> <p>E-MG-R125A</p> <p>$\phi 34.6$</p> <p>3.8</p> <p>45</p> <p>55</p> <p>$\phi 59$</p>	Roundness: 0.03 μm Diameter: Φ 40 mm Material: Quartz glass	Provided with wooden box.
Cylindrical square	E-MG-R06A	 <p>ϕA</p> <p>B</p>	Cylindricity: 1 $\mu\text{m}/150$ mm Squareness: 2 μm Dimensions: Φ 60 mm x Φ 150 mm	
	E-MG-R08A		Cylindricity: 1.3 $\mu\text{m}/200$ mm Squareness: 2.5 μm Dimensions: Φ 60 mm x Φ 200 mm	
	E-MG-R83A		Cylindricity: 2 $\mu\text{m}/400$ mm Squareness: 5 μm Dimensions: Φ 92 mm x Φ 400 mm	
High accuracy cylindrical square	E-MG-R87A		$\phi A, B$: Refer to size.	Cylindricity: 0.28 $\mu\text{m}/100$ mm Squareness: 2 μm Dimensions: Φ 60 mm x Φ 150 mm

 Standard Inventory Parts

Peripherals

Name	Model	External view	Specifications	Remarks
Water separator	L-WF-R08B			Dimensions: 100 mm (W) x 80 mm (D) x 280 mm (H)
Oil separator	L-WF-R07B		Filtration: 0.1 μm	Dimensions: 100 mm (W) x 190 mm (H) Weight: 1.7 kg
Air purifier set	L-WF-R11B		Install L-WF-R08B water separator, L-WF-R07B oil separator on mounting plate	Dimensions: 320 mm (W) x 170 mm (D) x 378.5 mm (H)
Refrigerating type air dryer	L-WF-R03C		Max. flow: 100 L/min Power consumption: 165 W/195 W (50 Hz/60 Hz) Weight: 15 kg	Dimensions: 200 mm (W) x 350 mm (D) x 400 mm (H) For AC 100 V
	L-WF-R27C		Max. flow: 200 L/min Power consumption: 210 W (50 Hz/60 Hz) Weight: 27 kg	Dimensions: 226 mm (W) x 410 mm (D) x 445 mm (H) For AC 200 V to 240 V Separate transformer type
	L-WF-R24B		Max. flow: 200 L/min Power consumption: 180 W/202 W (50 Hz/60 Hz) Weight: 18 kg	Dimensions: 226 mm (W) x 410 mm (D) x 473 mm (H) For AC 230 V CE marking

Standard Inventory Parts

Total Support Services

4 support services provided by Tokyo Seimitsu



Maintenance Pack Service

(maintenance contract)

Various maintenance packages are available to keep your machines in good conditions.

The maintenance packages will provide quick repair and reduce your unexpected cost burden when your machine fails.

If regular inspection is scheduled in your work plan, you can maintain the precision and functions of your measuring instruments, allocate inspection budget and cut wasteful expenditures.

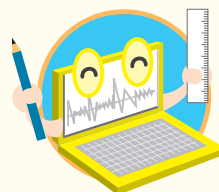

Program Creation Service

Tokyo Seimitsu offers the service from the program design for automatic measurement to the design and production of jigs to fix workpieces.

Designing automatic measurement programs requires many man-hours and increase burden.

This service will help you reduce these man-hours and burden.

* The service to design only the part program is available.



Inspection and Calibration Service

*1: ISO/IEC17025:2005 Registration No. 0047
International MRA accredited laboratory

Tokyo Seimitsu conducts the maintenance, inspection and calibration of your machines, and guarantees the machine quality and measurement results with inspection results and calibration certificates.

As an accredited laboratory (*1), Tokyo Seimitsu is authorized to provide JCSS calibration. (We can issue calibration certificates with JCSS mark on them.)

Inspection and calibration are recommended to maintain the precision of machines and use them for a long time.



Measurement Service

Tokyo Seimitsu conducts measurement, evaluation and analysis for customers.

When you do not have measuring machines but are required to conduct measurement/evaluation, or when your machines are not capable of conducting required measurement in terms of precision and size, Tokyo Seimitsu conducts measurement and support you.

These services are provided to:

Tokyo Seimitsu's
coordinate, surface roughness/profile shape,
and roundness/cylindrical shape measuring machines.



We reserve the right to change the contents of this catalog, including product specifications, without notice when products are updated.

Some of our products shall be controlled by the Foreign Exchange and Foreign Trade Act, and required an export license by the Japanese Government. Regarding exporting the products and/or providing a non-resident with technologies, please consult Tokyo Seimitsu.

<https://www.accretech.jp>

